



# Intelligent Grid

A value proposition for distributed energy in Australia

CSIRO Report ET/IR 1152

Enquiries should be addressed to:

Dr Bill Lilley ([bill.lilley@csiro.au](mailto:bill.lilley@csiro.au))

Previous Intelligent Grid Program Leader (seconded at time of publishing)

CSIRO Energy Technology

10 Murray Dwyer, Mayfield West, 2304

Mr Anthony Szatow ([anthony.szatow@csiro.au](mailto:anthony.szatow@csiro.au))

Current Intelligent Grid Program Leader

CSIRO Energy Technology

10 Murray Dwyer, Mayfield West, 2304

Mr Terry Jones ([terry.jones@csiro.au](mailto:terry.jones@csiro.au))

Low Emissions and Distributed Energy Theme Leader

CSIRO Energy Technology

10 Murray Dwyer, Mayfield West, 2304

## Copyright and Disclaimer

© 2009 CSIRO To the extent permitted by law, all rights are reserved and no part of this publication covered by copyright may be reproduced or copied in any form or by any means except with the written permission of CSIRO.

## Important Disclaimer

CSIRO advises that the information contained in this publication comprises general statements based on scientific research. The reader is advised and needs to be aware that such information may be incomplete or unable to be used in any specific situation. No reliance or actions must therefore be made on that information without seeking prior expert professional, scientific and technical advice. To the extent permitted by law, CSIRO (including its employees and consultants) excludes all liability to any person for any consequences, including but not limited to all losses, damages, costs, expenses and any other compensation, arising directly or indirectly from using this publication (in part or in whole) and any information or material contained in it.

# Contents

1.	Introduction .....	6
2.	Summary.....	7
2.1	Understanding distributed energy.....	7
2.2	Distributed energy as an early action response to climate change.....	11
2.3	The impacts and benefits of distributed energy on the NEM.....	18
2.4	Impacts and benefits of distributed energy on distribution networks.....	21
2.5	Impacts and benefits of distributed energy on transmission networks.....	23
2.6	Integrating distributed energy with the electricity grid .....	25
2.7	Enabling large scale uptake of distributed energy.....	29
2.8	Distributed energy and policy making.....	32
2.9	Decision making, consumers and distributed energy .....	34
2.10	Distributed energy business models.....	38
2.11	Integrating distributed energy with energy markets.....	42
2.12	Global trends in distributed energy.....	48
2.13	Distributed energy in Australia.....	53

## List of Figures

Figure 2.1: Schematic representation of a CHP system	8
Figure 2.2: A hypothetical daily demand profile including storage	9
Figure 2.3: Schematic representation of a solar based air conditioning system.	10
Figure 2.4: Comparison of energy costs with and without DE	12
Figure 2.5: National electricity generation under Garnaut 450ppm, 2006-2050	13
Figure 2.6: Distributed generation under Garnaut 450ppm, 2006-2050	14
Figure 2.7: Electricity sector greenhouse gas abatement, Garnaut 450ppm	15
Figure 2.8: Sensitivity of DG uptake	16
Figure 2.9: One-line diagram of IEEE RTS '96	24
Figure 2.10: A conceptual model of a “smart grid” containing minigrid elements	26
Figure 2.11: A conceptual framework for the Intelligent Grid	36
Figure 2.12: 15 minute average power (kW) consumption for a two week period in the base line year from the four businesses in the Maine’s power study	41
Figure 2.13: A hypothetical daily demand profile including storage	44
Figure 2.14: Potential barriers and drivers to participating in CC2	47
Figure 2.15: Proportion of electricity from DG (WADE, 2006). Reproduced with permission from WADE	48

## List of Tables

Table 2.1: Emissions Intensity Factor (EIF; t-CO <sub>2</sub> /MWh)	19
Table 2.2: NEM average spot prices (\$/MWh)	19
Table 2.3: Premium price of a \$100/MWh Base cap	20
Table 2.4: Electricity production sources in India (IEA, 2009a)	50
Table 2.5: Electricity production sources in China (IEA, 2009b)	51
Table 2.6: Current installations of renewable and distributed energy sources in India (MNRE, 2009)	52

## 1. INTRODUCTION

In response to climate change, Australia is developing a suite of options aimed at delivering more efficient and sustainable low emissions energy. One solution is distributed energy (DE; collectively demand side management, energy efficiency and distributed generation) which provides solutions near the point of use rather than at remote locations.

The Low Emissions and Distributed Energy (LEDE) theme of CSIRO's Energy Transformed Flagship is developing local solutions through a range of initiatives. These include intelligent control and aggregation of household and commercial appliances, optimisation of loads and generation in minigrid systems, development of an innovative household solar based air conditioner, construction of a zero emissions home and production of novel generation devices.

Wide scale deployment of distributed energy will require a revolution in engineering design, practice and regulation. To facilitate this change, CSIRO has investigated economic, social, environmental and technical barriers and enablers for wide scale adoption of DE. Results of these investigations are contained within this Intelligent Grid report which provides evidence of the critical role distributed energy can play in Australia's Energy future.

Realising the value of DE requires understanding and addressing the complex issues affecting key stakeholders including government, electricity and gas network businesses, energy retailers, small to medium enterprises, large energy users and domestic consumers. Critically important issues include the effects of DE on short and long term economic drivers; the effects of DE on networks through introduction of local grid connected devices; environmental sensitivities resulting from the change in technology type and the location of generation; the acceptance of DE by all forms of society; and the complex interaction with policy and regulation. By dealing with these issues, this report will help stakeholders understand the vital role DE can play in ensuring an affordable low emissions future.

## 2. SUMMARY

This report examines the economic, environmental and social aspects of using distributed energy technologies as an alternative to further centralised generation. Distributed energy is a term that describes technologies and systems which provide local generation of electrical power (distributed generation), energy efficiency and demand management functions. Distributed energy is a collection of technologies and systems that supply or substitute electrical power at the point of consumption close to load, with more efficient devices or systems that optimise and reduce the use of electricity thus reducing carbon emissions and improving infrastructure utilisation. This summary details the findings from the report that identify the potential contribution distributed energy can make to reduce greenhouse gas emissions in Australia, and how that potential can be realised.

### 2.1 Understanding distributed energy

Distributed energy describes a number of technologies that can significantly reduce the nation's greenhouse gas emissions. These reductions result from reduced network losses by using generation near the point of consumption, through maximising the use of cleaner fuel sources such as natural gas, solar and wind, and through more efficient conversion of fuels to useful energy services, including recovering heat otherwise wasted.

Distributed generation (DG), sometimes referred to as embedded generation is generally connected to the electricity grid at low voltage (< 22 kV). Internal combustion reciprocating engines (ICE) are the most mature prime movers for DG applications. Advantages include comparatively low installed cost, high efficiency (up to 45% for larger units), suitability for intermittent operation, high part-load efficiency, high-temperature exhaust streams for combined heat and power (CHP) and are easily serviced. These units have been popular for peaking, emergency, and base-load power generation. The units can run on a variety of fuels including diesel, natural gas, compressed natural gas and petrol. DG units connect to the grid as synchronous machines, asynchronous machines and or inverter generators depending on the primary source of energy. Synchronous generators are commonly used with engines and turbines. Asynchronous generators are commonly employed on medium and large wind turbines while solar photovoltaics and small wind turbines utilise DC/AC inverters to connect to the grid.

Cogeneration (see Figure 2.1) is a process where the heat generated by combustion of a fuel for electricity production is used for a secondary purpose rather than being a waste product. The heat is most often used to create hot water or steam but can also be used for cooling purposes through an adsorption cycle. Where heat can be used for cooling as well as heating, it is referred to as combined cooling and heating power (CCHP) or trigeneration. The value of co/trigeneration can be influenced by the type of technology, its reliability, the timing and size of the heating and cooling demand in respect to electrical needs, and the type of system the waste heat equipment is replacing or substituting.

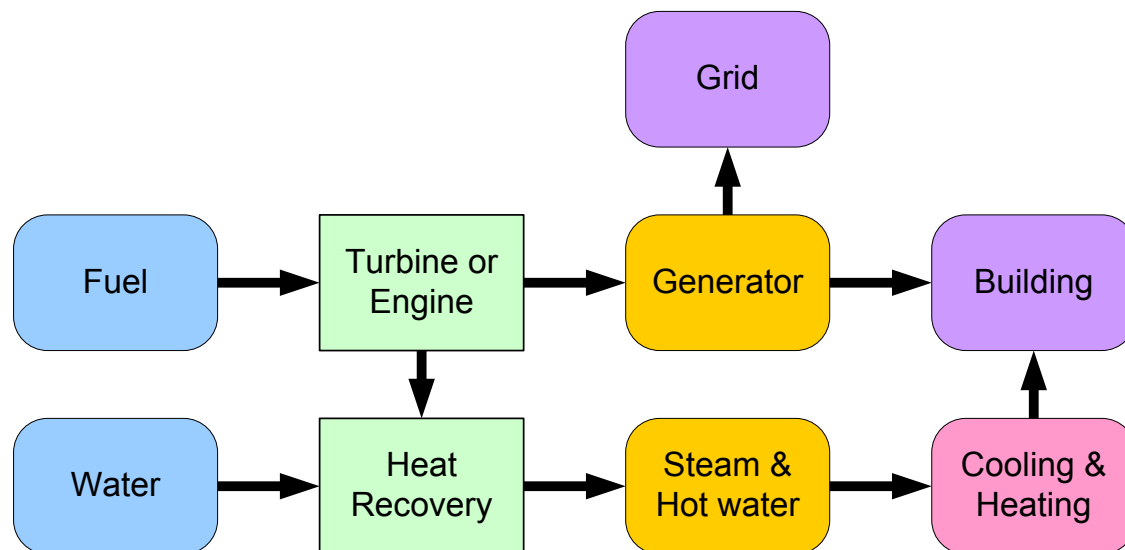

Figure 2.1: Schematic representation of a CHP system

Demand management refers to a suite of technologies and techniques used to actively alter demand profiles over time. While these measures may reduce total energy use, they are primarily employed to smooth or shift peaks in demand. By controlling peak energy patterns, demand management may provide substantial financial savings to consumers by reducing the need to build generation and network infrastructure required to service this peak demand for only a small number of hours each year.

A number of technologies are important for demand management. These are generally storage devices such as batteries, compressed air and thermal materials, or communication and control technologies that allow controlled cycling of appliances such as compression cycles in air conditioners or discretionary loads such as pool pumps to be turned off.

Storage devices take a variety of forms and can be used for many applications including maximising the value of intermittent, but predictable clean energy such as wind and solar power or mitigating the cost of peak demand at the distribution or transmission level. They do this by storing any energy produced at times of low demand and releasing it at times of high demand (see Figure 2.2). Storage options can include coordinating refrigeration cycles in large cold stores so that temperatures are dropped at times of low demand or high solar/wind output, and allowed to rise at times of high demand or low solar/wind output. Optimising the integration of low cost storage devices with alternative forms of generation and discretionary heat and power loads are likely to be critical to realising high penetrations of renewable and distributed energy in a cost effective way.



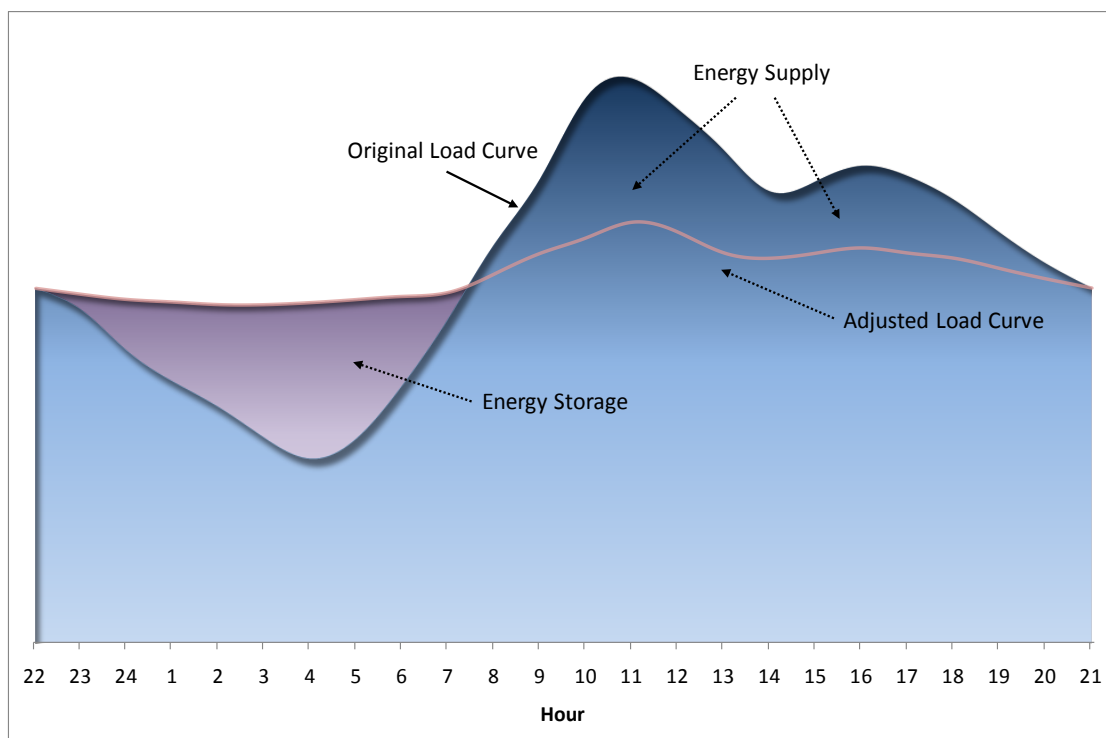

Figure 2.2: A hypothetical daily demand profile including storage

Energy efficiency can be thought of in a number of ways. In one sense, it is a reduction in energy demand as a result of changes in performance efficiency of individual devices or the substitution of one form of energy for another more efficient version (using solar energy for heating water for instance). In another sense, improvements to system efficiency are a form of energy efficiency. This could include the reduction of network losses by generating energy close to the point of consumption, or improving the utilisation of a fuel by capturing more of the energy available as occurs through cogeneration and trigeneration. Improving system efficiency can help reduce greenhouse gas emission and energy costs, but can also mitigate against fuel scarcity risks by creating better use of a limited quantity of fuel.

Energy efficiency is often seen as the easiest and most cost effective way to reduce greenhouse gas emissions in the short term. It is important to note that the value of energy efficiency is not only determined by the quantity of energy that can be saved, but the timing of those energy savings as energy market costs vary significantly over the course of the day with costs typically highest when demand peaks.

While all energy efficiency measures reduce energy consumption, or maximise the value of a given unit of available energy, their economic merit can vary depending upon the timing at which the efficiency gain is made. For example, solar hot water systems heat up during the day and store hot water in tanks. The greenhouse gas savings for these systems are greatest when replacing off-peak electric hot water units, as these units would otherwise draw on grid based electricity that is primarily coal fired. However this off-peak hot water system was developed to remove load from the network during the day when it is most stressed and to allow large coal-fired generators to operate continuously, thereby maximising their thermal efficiency. In this

## SUMMARY

way, off-peak electric hot water provides a service to the electricity industry which results in reduced energy prices.

The value of substituting off-peak electric hot water with a solar hot water system can be contrasted with a solar based cooling system. In this process, fresh (outside) air is dehumidified in a rotary desiccant wheel (see Figure 2.3). In this adiabatic drying process, the air is unavoidably warmed. A heat recovery heat exchanger is used to cool the warm dry air back down to near ambient temperature. The resulting pre-cooled, dry air stream is then further cooled to temperatures below ambient using an evaporative cooling process before it is introduced into the occupied space to provide the desired space conditioning.

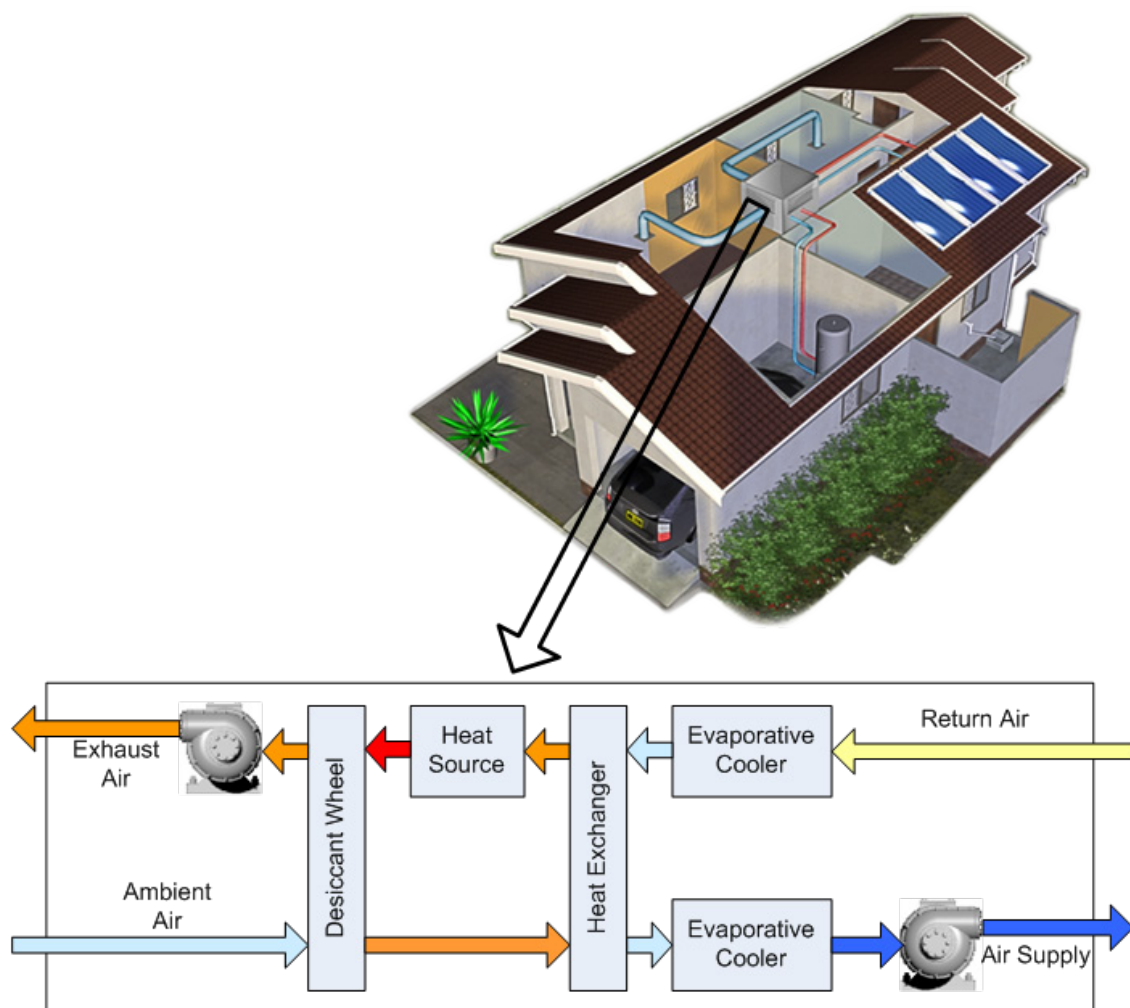

Figure 2.3: Schematic representation of a solar based air conditioning system.

There is an increasing acceptance that Australia's energy supply system needs to evolve in order to meet the dual challenges of energy security and climate change. Smart grids which incorporate distributed energy solutions with large scale renewables and information infrastructure are expected to provide a future system able to meet the growing demand for energy while ensuring low emissions and high levels of security.

## 2.2 Distributed energy as an early action response to climate change

Four carbon mitigation scenarios were analysed using CSIRO's Energy Sector Model (ESM), a bottom-up model of the electricity and transport sectors in Australia. It has a detailed representation of the electricity generation sector with substantial coverage of DG technologies.

Scenarios tested were based on different policy proposals that have been considered in public debate, including those currently being considered by the Australian Government. In brief, these scenarios are as follows:

**CPRS -5:** A carbon pollution reduction scheme is adopted, commencing in 2010, with an emissions allocation that leads to a reduction in emissions of 5 per cent on 2000 levels by 2020 and 60 per cent below 2000 levels by 2050.

**CPRS -15:** A carbon pollution reduction scheme is adopted, commencing in 2010, with an emissions allocation that leads to a reduction in emissions of 15 per cent on 2000 levels by 2020 and 60 per cent below 2000 levels by 2050.

**Garnaut 550ppm:** An Australian emission trading scheme is adopted, commencing in 2013, with an emissions allocation that leads to a reduction in emissions of 10 per cent on 2000 levels by 2020 and 80 per cent below 2000 levels by 2050 for stabilisation at 550 ppm.

**Garnaut 450ppm:** An Australian emission trading scheme is adopted, commencing in 2013, with an emissions allocation that leads to a reduction in emissions of 25 per cent on 2000 levels by 2020 and 90 per cent below 2000 levels by 2050 for stabilisation at 450 ppm.

Results from the ESM modelling show that distributed energy has a significant role to play in a carbon constrained future. On the basis of technology characteristics and cost competitiveness, the economic modelling indicates that DG can significantly increase its share of energy supply in the near-term, decreasing the need for additional centralised generation and reducing the emission intensity of energy supply. The estimated technology uptake suggests that DG has a bridging role in transitioning from the current coal dominated system while large-scale renewable and near-zero emission carbon capture and storage technologies are either too expensive or unproven. In this way, distributed energy is found to be an attractive early action response to climate change.

To develop a sense of the welfare gain provided by distributed energy, we compared two scenarios. The base case is Garnaut 450ppm with baseline growth in electricity accounting for energy efficiency and structural economic change, distributed generation included as an option, and demand endogenous in the model, so affected by price elasticity of demand for different end users. The alternative case is Garnaut 450ppm, with baseline growth in electricity demand set at business as usual (BAU) levels, DG not included as an option, and demand fixed (perfectly inelastic).

The difference between the two gives a measure of the value (welfare gain) of energy efficiency, demand management, distributed generation and structural change in the economy. The model cannot distinguish between energy efficiency and structural change in the economy.

## SUMMARY

Over the period 2006-2050, the undiscounted value of energy efficiency, demand management, distributed generation and structural change is around \$800b (currently Gross Domestic Product in real terms is around \$1,100b). This saving is calculated by measuring the difference in weighted average prices multiplied by energy consumed between scenarios modelled. The present value of the welfare gain is around \$130b discounted at 7% pa. Ultimately, these benefits are shared by all consumers of electricity.

Figure 2.4 below illustrates how this value accrues over time. The blue line represents total energy costs where distributed energy is excluded as an option in the model, the red line represents total energy costs where distributed energy.

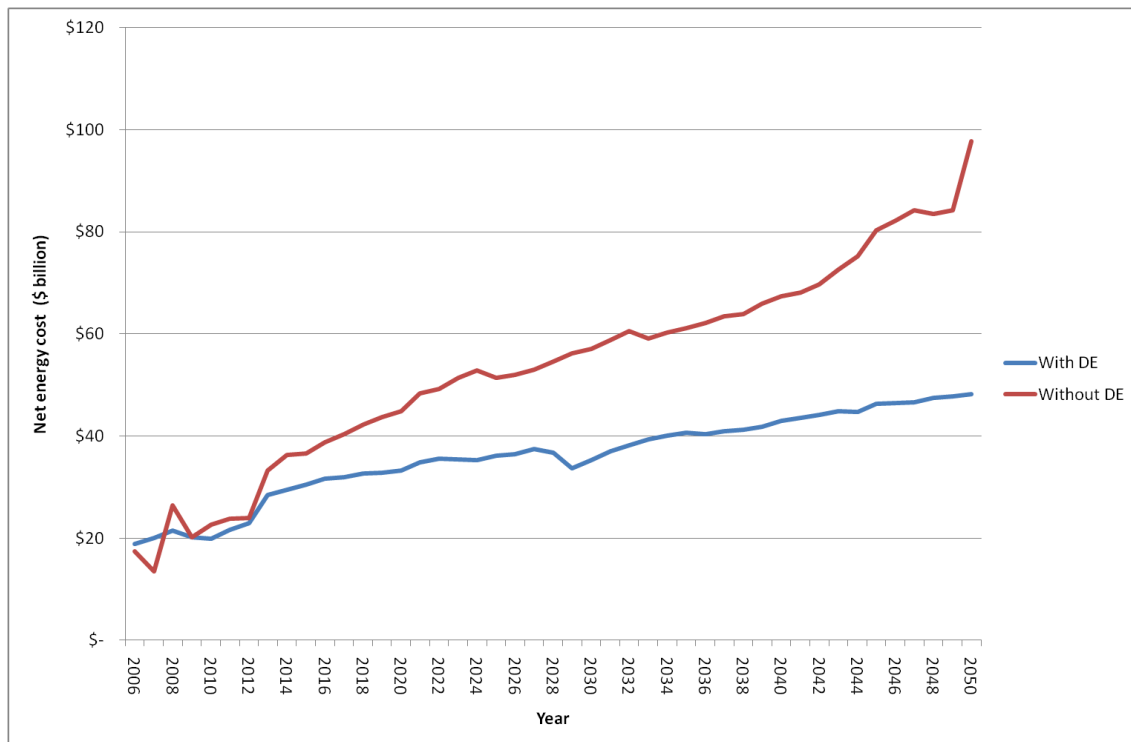

Figure 2.4: Comparison of energy costs with and without DE

It is important to note that the only major cost the ESM doesn't account for is the cost of structural change in the economy over time. Costs associated with transforming the energy supply chain are built into the model and so can effectively be considered zero. The model optimises by requiring a 7% rate of return on energy assets over their lifetime.

Fully valuing distributed energy based on avoided or delayed spending on network and generation infrastructure is a complex exercise that is not fully captured by the ESM. The ESM captures avoided spending on peak generation infrastructure, and transmission networks to a degree, but imperfectly due to modelling limitations. Previous attempts have been made to quantify the market value of demand management specifically excluding network benefits, with estimates ranging from \$363M - \$954M over the period 2007 – 2025 (Hoch et al. 2006).

Water savings are also made in the Garnaut 450ppm scenario through a mix of distributed energy and renewables, with approximately 200 gigalitres saved per annum in 2030 and 375

gigalitres saved in 2050. While this appears relatively small compared to Australia wide water consumption (around 1%), it significantly reduces the exposure of energy wholesale markets to potential water shortages, with an approximate 66% reduction in water intensity of electricity supply by 2030 and 83% by 2050. This is likely to have significant risk management value, potentially resulting in lower prices for consumers, but also competitive advantage for suppliers and consumers of distributed energy where they compete with mains grid supply. We note water shortages in 2007 helped drive an approximate doubling of wholesale prices.

In all scenarios modelled, the relative contribution each technology makes to emission reductions remains relatively constant with the main difference being the timing of technology deployment and the increase in electricity demand caused by the emergence of plug-in hybrid and fully electric vehicles. For example, in the Garnaut 450ppm scenario, it is estimated by 2050 these vehicles will account for over half of road kilometres travelled. Mild hybrids which generate their electricity on board rather than drawing on the electricity grid, are projected to account for another 20 per cent of the fleet, leaving internal combustion vehicles accounting for around 17 per cent of kilometres travelled. The electricity generation mix projected in the Garnaut 450ppm scenario is presented below.

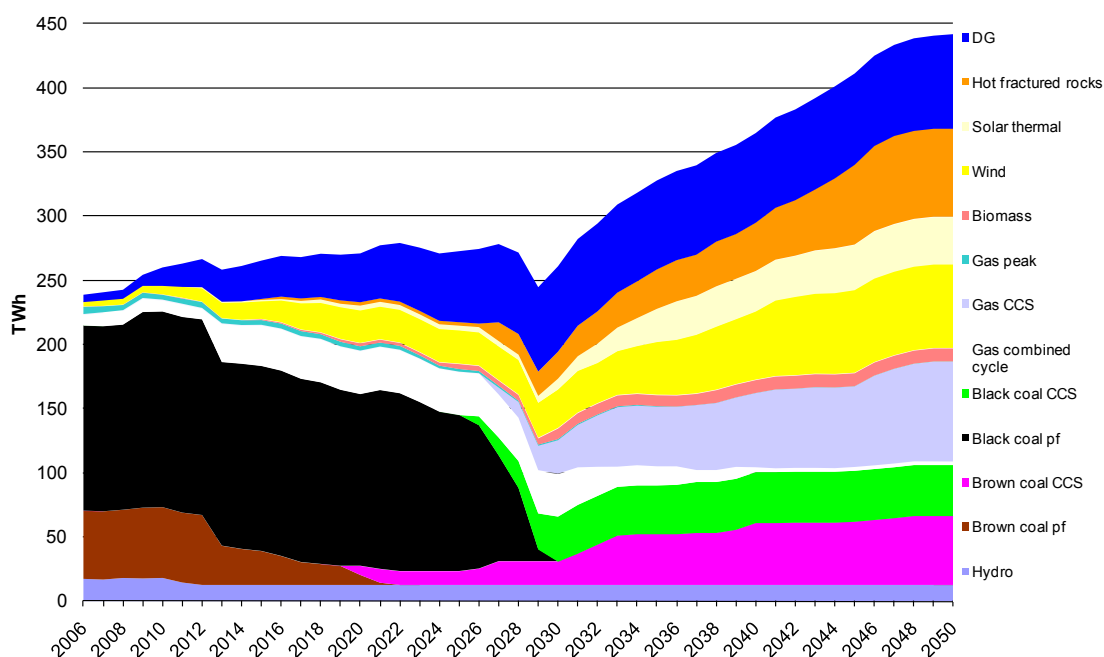

Figure 2.5: National electricity generation under Garnaut 450ppm, 2006-2050

It is of interest to note the drop in demand that occurs around 2030 as black coal is phased out and replaced by low-emission technologies (Figure 2.5). This negative demand shock may be less severe under real world conditions, but it highlights the difficulty in meeting aggressive emission cuts through the supply-side without constraining demand in some way. It is worth noting the model does incorporate significant levels of energy efficiency, detailed in Figure 2.7.

Figure 2.6 represents the breakdown of distributed generators forecast under the Garnaut 450ppm scenario by the model. It can be seen that initially, biomass and gas fired combined

## SUMMARY

heat and power systems are most prevalent, with trigeneration in commercial buildings coming online in the very short term, before solar PV systems dominate growth in DG from 2018 onwards. It is important to recognise this type of scenario forecasting is not a prediction of real world events, but indicative of how they may play out should a certain scenario eventuate.

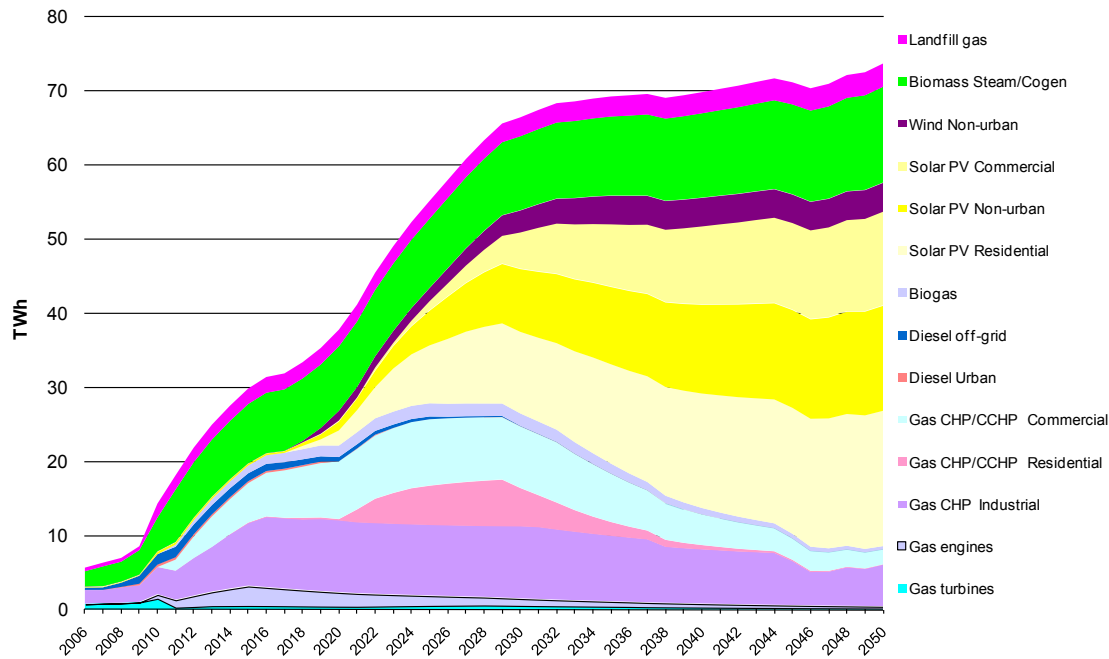

Figure 2.6: Distributed generation under Garnaut 450ppm, 2006-2050

An important feature of the model results is the relative contribution to emission reductions achieved by the mix of technologies, including energy efficiency. It can be seen that DG has a greater role to play in the near-term before other low emission technology options are competitive or available (Figure 2.7). However, as expected, energy efficiency remains a very important contributor to emission reductions in the short and long term.

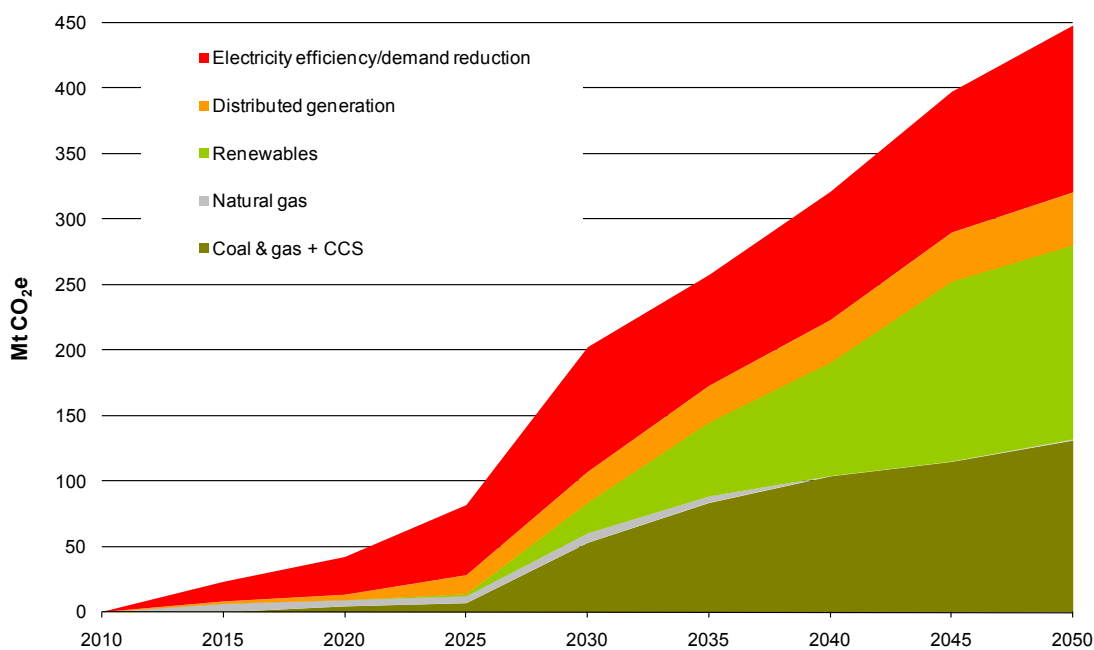

Figure 2.7: Electricity sector greenhouse gas abatement, Garnaut 450ppm

A number of sensitivity analyses were conducted to determine variations that may result from a future in which carbon capture and storage technologies are unavailable; where capital costs of alternative options are higher or lower than expected, and where the deployment of DG technologies can roll out faster than expected. Figure 2.8 which shows the range in distributed energy that can result from different modelling assumptions highlights the importance of ensuring a portfolio of technologies are developed that can be integrated within energy market constraints.

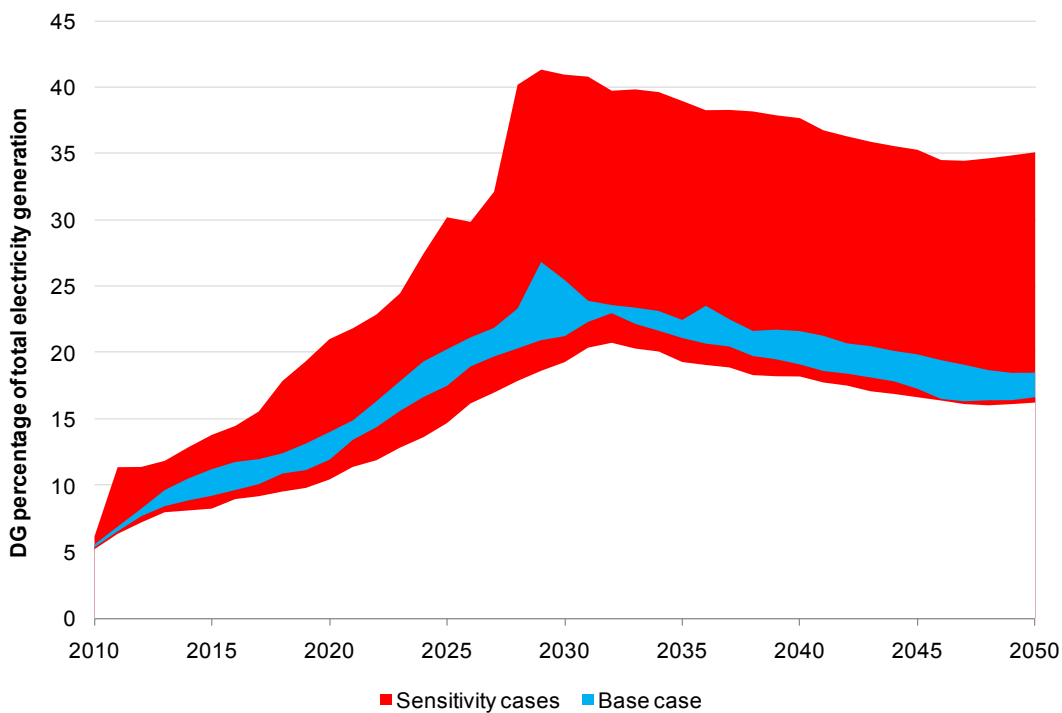

Figure 2.8: Sensitivity of DG uptake

In general, DG appears to be an effective early action greenhouse gas mitigation option for Australia when it is considered within a portfolio of other mitigation options. This is principally due to a number of factors:

- There are numerous low-emission DG technology options that are commercially available
- There are DG technologies which utilise waste heat that is lost in centralised electricity generation, increasing overall fuel energy efficiency
- DG options have less lead time in comparison to brown- or green-field expansions of centralised plant
- DG options are modular and can be tailored to individual end-user requirements
- Some DG options utilise fuel that is uneconomic for large centralised plant (e.g., landfill gas, waste streams, some forms of biomass)
- DG options are more able to match growing demand by installing smaller more appropriately sized units while centralised technologies result in large stepwise additions of supply
- DG options provide a mechanism to reduce electrical losses in transmission and distribution by locating the units close to the point of end use.

More specifically, the results indicate that:



- In the near-term, co- or trigeneration technologies using natural gas or biomass/biogas appear to be the most cost effective options, especially in the industrial (natural gas, waste gas, coal seam methane), commercial (natural gas and biogas) and rural (biomass) sectors. They provide a vital bridge towards a low carbon future
- Landfill gas and waste gas reciprocating engines are competitive but are limited by fuel availability
- Small scale wind turbines are more competitive in non-urban areas where alternatives are more expensive or better wind resources are available
- In the medium-term, there is potential for significant deployment of photovoltaic (PV) technology in the residential, rural and commercial sectors. The estimated uptake has implications for employment
- In conjunction with energy efficiency and demand reduction, DG is the most cost effective greenhouse gas mitigation option in the near- to medium-term contributing between 4 to 18 Mt of abatement in 2020 and 23 to 40 Mt of abatement in 2030
- Sensitivity analyses indicated that the more rapidly DG technologies can get down the cost curve (i.e., technological breakthrough, imported learning) the more competitive these options are to other alternatives
- Should large scale low emission technologies prove unworkable or too expensive there appears to be some scope for DG to lessen negative impacts such as higher electricity prices
- Significant co-benefits resulting from the deployment of distributed energy solutions can be found in reduced water consumption and pollutant emissions such as NO<sub>x</sub>, SO<sub>2</sub> and PM<sub>10</sub>.

The modelling results need to be interpreted with some caution. Some key limitations of the modelling include:

- The modelling framework considers cost effectiveness and a limited set of constraints in projecting technology uptake. In reality community concerns and many other non-price factors not included in the modelling will influence the future technology choices individuals and businesses make
- Not all DG technologies are included in the modelling because of the difficulty of establishing a future price (e.g., mini-hydro and Stirling CHP)
- Assumed capacity factors for each technology are fixed and only partially account for spatial variation.

## 2.3 The impacts and benefits of distributed energy on the NEM

The commercial software package PLEXOS (<http://www.plexossolutions.com/>) was used to examine the impacts of distributed energy on the National Electricity market (NEM) for a future in which distributed energy plays a large and significant role in reducing Australia's greenhouse emissions. The modelling performed by the University of Queensland (UQ; Wagner, 2009) examined the outcomes on the NEM resulting from installed capacities of DG technologies predicted by ESM for the CPRS-15 and Garnaut 450 ppm scenarios.

The effects of distributed energy in the NEM were considered by running five case studies representing policy frameworks in three landmark years, namely 2020, 2030 and 2050.

**Business-As-Usual (BAU) case with no carbon trading:** in which carbon pricing is not implemented. Load growth is met by significant investment in large centralised generation assets such as base load coal, combined cycle gas turbines (CCGT), solar thermal, geothermal (hot fractured rocks) and wind turbines

**CPRS -15% no DG:** The CPRS is introduced in combination with the renewable energy target to reach an overall reduction of emissions by 15% below 2000 levels. The price of emissions permits reaches approximately \$50 t/CO<sub>2</sub> in 2020. Demand growth is reduced compared to the reference case given the increase in energy costs following the implementation of the CPRS. Increased renewable generation asset deployment is observed in this scenario compared to the BAU reference case

**Garnaut 450ppm no DG:** The introduction of the CPRS with a deeper emissions abatement pathway is implemented to achieve an overall reduction of emissions of 25% below 2000 levels. The emissions permit price reaches around \$61 t/CO<sub>2</sub> in 2020 which will place more pressure to achieve further energy efficiency and lower emissions technology deployment across the NEM

**CPRS -15% with DG:** Following the introduction of the CPRS, emissions permit prices stimulate the deployment of small scale DG technologies. The roll out of small scale decentralised generation will allow for additional cuts in emissions than the corresponding CPRS -15% case study

**Garnaut 450ppm with DG:** With the implementation of deeper cuts to emissions following the introduction of a 25% target via the CPRS, higher permit prices stimulate a variety of alternative DG options for deployment across the NEM. Furthermore, increased pressure from permit prices reduces demand, resulting in a decreased reliance over time on centralised higher emitting generation types.

Modelling performed with PLEXOS indicates that the Emissions Intensity Factor (EIF; t-CO<sub>2</sub>/MWh) of delivered energy throughout the NEM is significantly reduced across all three years, and under both emissions reduction scenarios, when DG has been considered. The EIF was chosen as the benchmark for analysis to better reflect emissions behaviour given the different rates of load growth across all scenarios. Table 2.1 features the EIF's of delivered energy across the NEM and shows significant structural change with respect to the emissions profile, demonstrating that DG could have a significant impact on curtailing CO<sub>2</sub> emissions.

Table 2.1: Emissions Intensity Factor (EIF; t-CO<sub>2</sub>/MWh)

	<b>Scenario 1</b>	<b>Scenario 2</b>	<b>Scenario 3</b>	<b>Scenario 4</b>	<b>Scenario 5</b>
<b>2020</b>	0.878	0.944	0.791	0.776	0.795
<b>2030</b>	0.932	0.429	0.500	0.390	0.433
<b>2050</b>	0.970	0.140	0.310	0.110	0.210

With the introduction of the CPRS, wholesale electricity prices are set to increase to meet the marginal cost increase imposed by a carbon price. Consequently, modelling results indicate that the marginal increase in electricity prices will vary depending on the price setting generation unit. While there is a significant increase in electricity prices for Scenario 2 (compared to the reference case), it should be noted that there is a significant shift in installed generating assets.

For example the installed capacity of low-cost coal-fired generation in the reference case will ensure that energy prices remain relatively low especially with brown coal generators having a LRMC of less than \$30/MWh. Conversely the increased cost of the generation types such as Combined Cycle Gas Turbines (CCGT) contributes greatly to the observed average price. Furthermore, the difference in prices between Scenario 2 and 3 (see Table 2.2), are due to the lower demand and generation mix changes due to the higher carbon price observed for a 25% carbon abatement pathway.

Table 2.2: NEM average spot prices (\$/MWh)

<b>NEM</b>	<b>Scenario 1</b>	<b>Scenario 2</b>	<b>Scenario 3</b>	<b>Scenario 4</b>	<b>Scenario 5</b>
<b>2020</b>	\$26.92	\$104.72	\$68.68	\$47.21	\$37.94
<b>2030</b>	\$36.66	\$55.87	\$54.97	\$35.46	\$32.40
<b>2050</b>	\$110.74	\$110.10	\$203.17	\$38.67	\$52.20

The modelling indicates that the roll out of DG will have a significant impact on the average spot price of electricity throughout the NEM. The drop in average spot prices for each of the DG scenarios indicates that investment in new technology stimulated by the CPRS will lower the delivered energy cost across the NEM.

The modelling indicates that another benefit of the roll out of DG is lower volatility of observed prices on the wholesale market. Lower volatility of spot price behaviour also provides significant benefits from a risk management perspective and reduces the cost of serving the retail consumer base. Valuing the premium on a \$100/MWh base cap product is a simple method of measuring market participant's exposure to high and volatile prices (see Table 2.3).

## SUMMARY

Table 2.3: Premium price of a \$100/MWh Base cap

<b>NEM</b>	<b>Scenario 1</b>	<b>Scenario 2</b>	<b>Scenario 3</b>	<b>Scenario 4</b>	<b>Scenario 5</b>
<b>2020</b>	\$25.75	\$64.19	\$68.00	\$39.18	\$26.77
<b>2030</b>	\$24.69	\$52.04	\$54.96	\$35.40	\$32.38
<b>2050</b>	\$44.79	\$30.70	\$53.56	\$29.36	\$40.09

With the deployment of DG, there is a decrease in the incidence of prices above \$100 throughout each simulated year. In the NEM, the frequency and severity of high prices has been observed on the market in previous years which has resulted in adverse consequences for the viability of retailers to recover the price of wholesale electricity from their customers. Lower spot market price volatility should result in lower tariff price increases over the planning horizon and the deferral of investment in expensive higher emitting peaking generator plant.

## 2.4 Impacts and benefits of distributed energy on distribution networks

A study performed with Senergy Econnect examined the impact of a high DG penetration on distribution networks (Senergy Econnect, 2009). A quantitative analysis was performed using power system modelling techniques on four real-world distribution feeders (data provided by SP Ausnet). The feeder case studies are assumed to be typical of the class they represent and have the following characteristics:

**Feeder 1:** Urban established commercial feeder, supplying predominantly commercial zones in an established urban area

**Feeder 2:** Urban established residential feeder, supplying predominantly residential load in a long-established urban area (to account for incremental network augmentation in response to evolving electrical applications over a period of decades)

**Feeder 3:** Urban green-field residential feeder, supplying developing residential subdivisions. This feeder will contain some rural and semi-rural load including some Single Wire Earth Return (SWER) circuitry but be evolving toward predominantly urban use

**Feeder 4:** Rural feeder, containing a combination of three-phase and SWER circuits.

Detailed power system analyses for large DG penetrations on the four feeder networks found that:

- DG is of benefit in reducing distribution network losses and improving voltage profiles
- DG is of some value in postponing network upgrades where thermal limits are a critical factor, although attention must be given to the effective capacity contribution under peak loading conditions. Network upgrades may be necessary in any case due to reliability considerations (value of lost energy), but depending on DG characteristics it may be possible to upgrade feeders with lighter conductors than would otherwise be necessary
- Under the investigated scenarios to 2050, DG is unlikely to pose widespread issues with fault current capacity of existing equipment, or to raise issues with protection coordination through displacement of conventional generation leading to reduced fault levels
- The envisaged embedded generator technologies are not considered to be a significant source of voltage flicker, rapid voltage change or phase imbalance. Harmonic emissions from inverter-connected generators such as PV are expected, but are unlikely to result in harmonic distortion on feeders in excess of regulatory limits
- The opportunity for power from DG to result in a power flow reversal across zone substation MV busbars is limited due to the fact the embedded generators have a tendency to generate at times of human activity and so energy consumption. As such it is considered unlikely to be a problem
- High-level investigations indicate that DG is unlikely to pose issues due to steady-state voltage stability, frequency stability, rotor angle stability or small-disturbance (oscillatory) stability. However, these investigations are limited and more detailed investigations are warranted in future to confirm these results

## SUMMARY

- Fault ride-through capabilities have been found to be desirable for DG but not necessary at the present or prior to 2050 given the high level assessment applied here.

A qualitative analysis considering the impact of policy and regulation found that:

- Currently, due diligence assessment of each individual embedded generator connection is required by the distribution network service provider (DNSP), if the DNSP foresees the potential for adverse network impacts. This could become impractical as the rate of connection requests increases. It is suggested that in future, an aggregated due diligence assessment might be undertaken instead based on an anticipated penetration of embedded generators. This would establish a level of DG that could connect without further assessment before network limits are reached
- The safety standards which are currently in place to achieve safe operation of distribution feeders are considered to remain appropriate for DG into the future. However, the protection philosophies and settings of existing equipment may need reconsideration, and some equipment may need to be upgraded, as embedded generator installations increase in number
- DG at present largely falls outside the scope of the National Electricity Rules generator technical requirements. There is some technical justification for extending some of these requirements to embedded generators as penetration increases toward 2050
- Given the level of interaction suggested between DNSPs, local electricity retailers, and embedded generators of all types, it can be expected that a myriad of contractual arrangements may be required between parties. It is suggested that arrangements should prioritise system security.
- Islanded operation of distribution networks is in principle highly effective in realising the full value from embedded generation. However, the technical and commercial barriers to such operation remain formidable and will require substantial work to address. It is reasonable to expect that islanded operation of networks will become feasible prior to the 2050 time horizon used in this study.

## 2.5 Impacts and benefits of distributed energy on transmission networks

The effects of DE on transmission systems were considered by examining the impact of passive DG installations within an Institute of Electrical and Electronics Engineers (IEEE) standardised transmission test grid (Figure 2.9). While the IEEE test grid is used extensively in gauging the performance of power system models, it is important to recognise this test grid is not based on real conditions of any Australian electricity grids. As such, the results are indicative of the behaviour of transmission networks to the installation of passive DG rather than a measure of impact in Australian grids to specific installations of DE.

The study examined the impact of passive constant DG on the economic dispatch of units within the system to determine the effects on the transmission systems using a full AC power flow model. Three simple case studies were used to examine the impact from increasing amounts of passive DG installed within the system. In two cases the DG was installed at isolated buses (transmission connection points) within the grid (Alder and Arne) and in the third case DG was spread throughout the entire network.

Modelling performed in this study found that adding constant passive DG to the IEEE test grid results in reduced congestion and a moderation of the price of electricity. Somewhat surprisingly, the modelling found that system wide transmission losses could increase. Changes to demand were found to significantly alter the merit order of the bids in the dispatch process. In some cases this results in electricity being routed through longer transmission lines or lines with different ratings. This can result in increased losses compared to the base case.

In general, capacity utilisation and net energy benefit were affected by the addition of DG, there were however some notable exceptions:

- The utilisation of nuclear, hydroelectric, and the largest coal units remained largely unaffected by DG. However, as electricity prices decline markedly once DG capacity is installed, the net energy benefit realised by these units decreased
- In most scenarios, the utilisation of the #6 fuel-oil conventional steam units at Arne is higher with DG installed. And, this increase is more than sufficient to offset the lower electricity prices; units at Arne are often more profitable with DG installed in the system than without it.

Further findings from the modelling include that:

- Adding even small amounts of DG can have dramatic impacts on the power flows and economics of an electricity system. For example the modelling found that 20 MW<sub>e</sub> of DG; a small amount (approximately 0.6% of total system capacity), installed at one location can reduce the average electricity price by 12%
- The effects of adding DG aren't limited to the bus at which the capacity is installed. They are felt by pre-existing generation units both near and far and, from generators' perspectives, can be positive or negative
- The effects of adding DG may depend more upon where the DG is added than on how much

SUMMARY

- The effects of adding DG depend quite heavily upon specific characteristics of the target electricity system (e.g., disposition of sources and sinks relative to one another, types of generation units in the system, electricity demand).

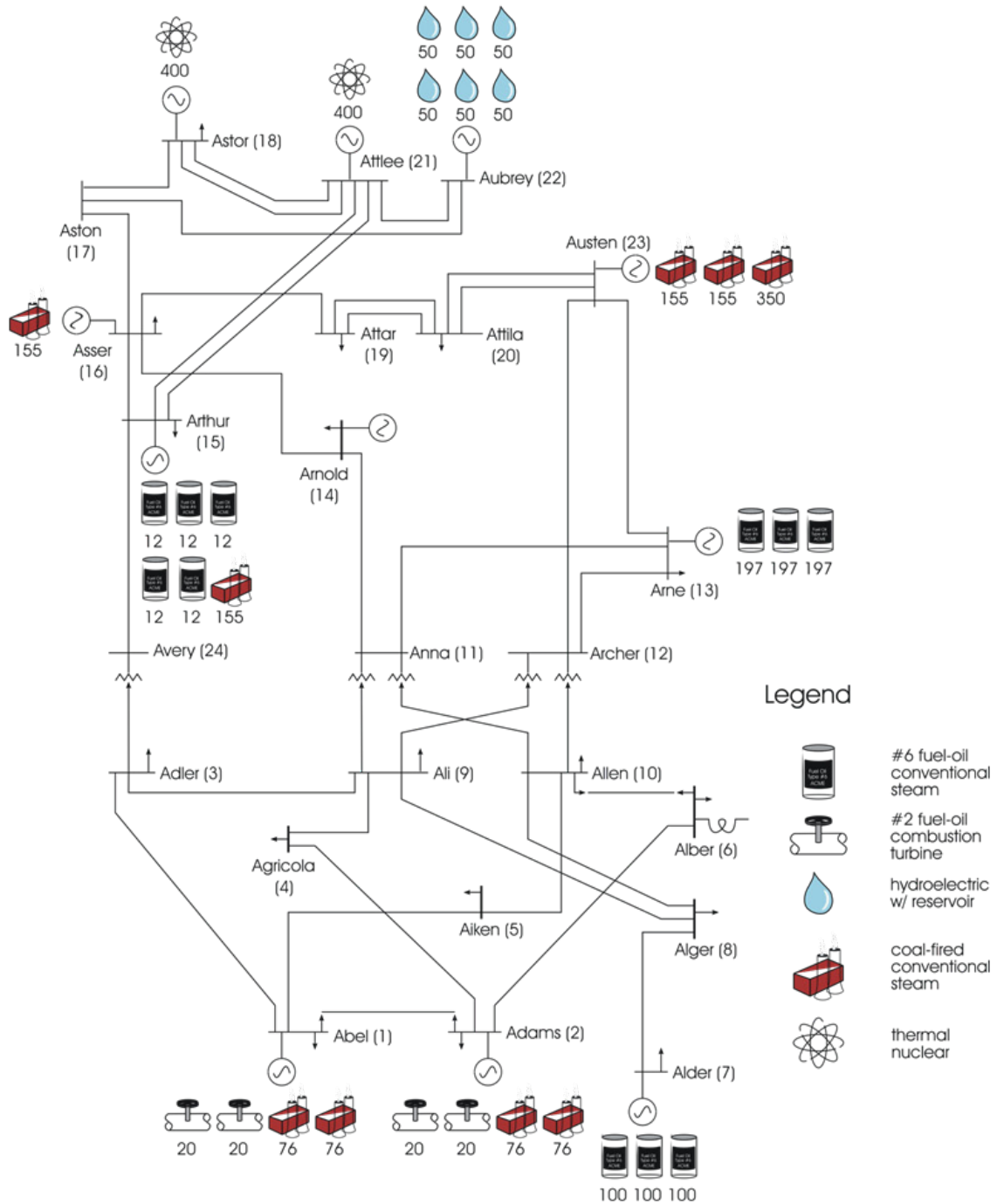

Figure 2.9: One-line diagram of IEEE RTS '96



## 2.6 Integrating distributed energy with the electricity grid

Realising the value of distributed energy can be achieved through many system configurations. One concept that is being increasingly accepted is that the electricity grid may need to evolve in order to meet the dual challenges of energy security and climate change. “Smart grids” which incorporate distributed energy solutions with large scale renewables and information infrastructure are expected to provide a future system able to meet the growing demand for energy with large elements of intermittent renewables and high levels of security.

In Australia and abroad, there is a growing movement which advocates that smart grids are the logical progression which will allow the electricity network to function in the most efficient economic manner, while supporting environmental and social needs. A smart grid optimally delivers electricity (and potentially other resources such as natural gas, water, heat etc) from suppliers to consumers using digital technology to save energy, reduce cost and increase reliability. As such, it is a way of addressing energy security and/or global warming issues by:

- Accommodating all forms of energy generation and storage
- Enabling new energy services
- Providing high power quality
- Optimising asset utilisation
- Anticipating and responding to system disturbances, and
- Operating resiliently against attack and natural disaster.

Figure 2.10 provides a conceptual model of a smart grid which incorporates minigrids. The minigrid is one of a number of available concepts that allows better integration of local devices through control and aggregation of technologies without requiring substantial change to existing infrastructure. It does this by connecting to the wider grid through a single point of common coupling. The larger grid is isolated from the interaction of devices and loads within the minigrid which are controlled locally. The figure shows a backbone of large scale electricity generation, transmission and distribution together with distributed energy resources and communication technologies which enable local supply, load control, asset optimisation and system resilience. The high voltage grid remains important in Australia to support the introduction of centralised renewable options such as geothermal and wind power, which are located at considerable distance from the major population centres. The inclusion of distributed energy resources and communications are the two defining features that set apart the smart grid from the current system.

## SUMMARY

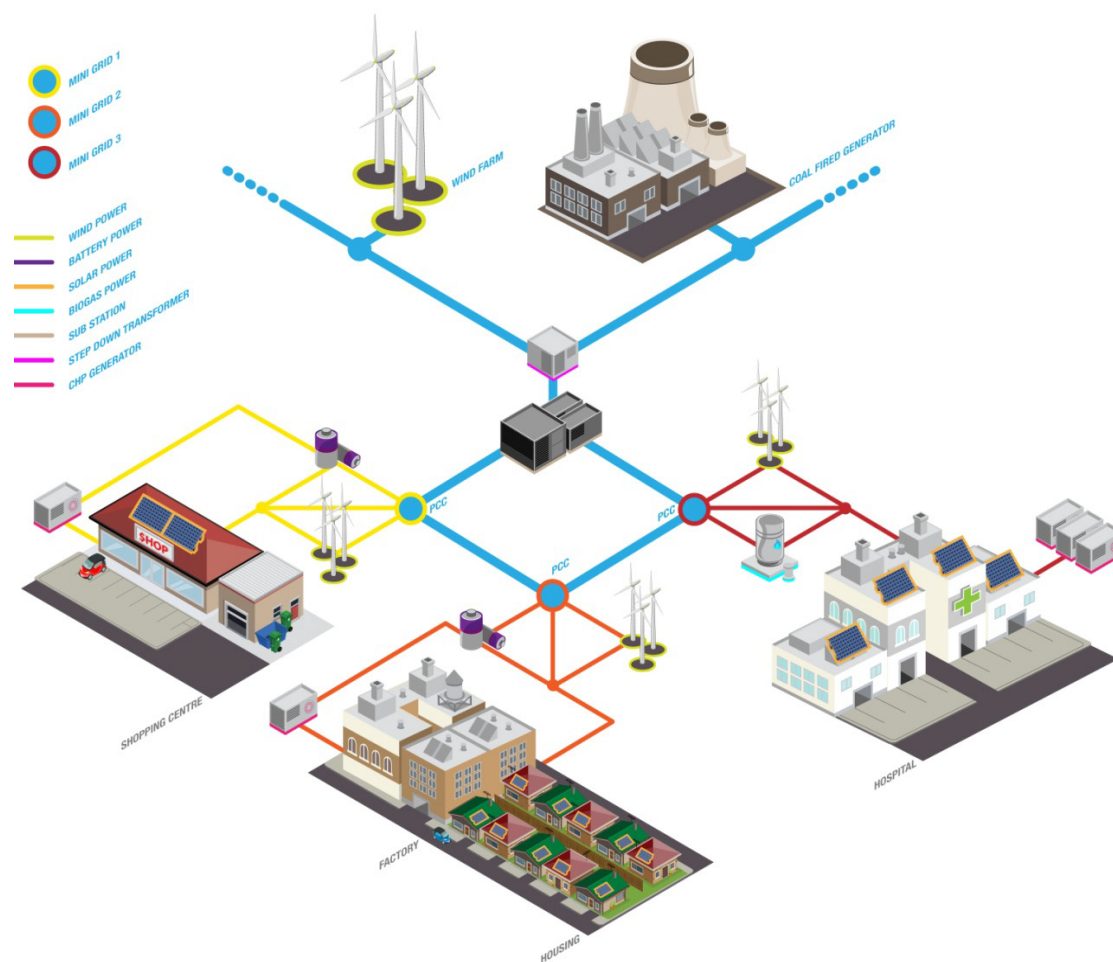

Figure 2.10: A conceptual model of a “smart grid” containing minigrid elements

Some of the key technical considerations when trying to incorporate high levels of distributed energy into the network are issues relating to the connection of generators, and the effect DG can have on network performance.

In Australia, network service providers (NSPs) operate, maintain and upgrade their infrastructure based on forecast growth over a five-year cycle. These forecasts are used to determine the amount of spend required to meet demand and are subject to regulatory checks. Previously these economic checks were performed by State based entities, but are now performed by a national authority; the Australian Energy Regulator (AER).

The AER determines how much DNSPs can receive in revenue by setting a price or revenue cap for electricity sales. This cap represents the regulator’s view on what is reasonable for DNSPs to charge customers for the delivery of electricity. This revenue forms part of the total electricity bill and is known as the distribution use of system charge (DUoS). The price or revenue cap is set at the beginning of each five-year determination.

A vital component of the AER’s determination is a prediction of peak and base demand provided by the DNSP. Any changes to the network demand within a regulatory cycle that results from activities such as demand management or DG can affect this determination and

shortfalls in forecast throughput may operate as a real or perceived penalty for the business under the price or revenue capping regulation. Similarly, the introduction of a large load mid-cycle could lead to significant concerns for the DNSP if their system does not have sufficient redundancy built in.

The effect of unplanned demand management on distribution business revenue is a contested issue. In its stage 2 draft report into barriers to demand side participation, the Australian Energy market Commission (AEMC) effectively takes a position that any loss of revenue felt by a distribution business acts to discipline them only to provide efficient demand management. Their rationale appears to be that demand management entails a customer foregoing energy consumption, and so lost network revenue reflects the social cost of not consuming.

The process for connecting distributed generation and allocating costs is currently being reviewed as part of a number of parallel processes including the energy market reform process. It is likely that any changes driven by this reform will take time to resolve due to the complex nature of the issue.

A contentious point in the connection of distributed generation has been the allocation of “shallow” or “deep” connection costs. This issue has been raised in many submissions to government authorities in reviews, both locally and internationally. At present there is no standardised definition across Australia in this regard. It appears that only Victoria has formally defined the difference in their Electricity Industry Guideline No. 15 (connection of embedded generation). In this document, the cost of connecting a local generator to the nearest point in a network is referred to as a “shallow” connection charge. A circuit breaker used exclusively by the generator for instance would fall into this category. This cost might not fully reflect system reinforcement upstream that may be required to allow the safe implementation of the device. These additional costs are considered by some as “deep costs” and in some areas may be passed onto the connecting generator. Guideline 15 states that in Victoria, shallow costs for the connection are those associated with connection assets and any augmentation of the distribution system up to and including the first transformation in the distribution system. Furthermore, the guideline states that deep costs beyond this point cannot be allocated to the local generator. A National framework for the allocation of shallow and deep connection costs is subject to current review and remains important to resolve.

While the Victorian example of a connection process appears reasonably simple in design, costs can vary depending upon the timing of connection. Consider a number of proponents that wish to connect to a network over time. The first proponent may find that the system can easily cater for their introduction. At a later time, a second proponent may wish to connect to the network. In this case, the DNSP’s ability to cater for their introduction will have been altered by connection of the first proponent. In this case, they may find that their proposed connection requires changes in the network such as replacement of a circuit breaker at the next highest voltage level due to increased fault levels. These costs which fall within the definition of a shallow charge may have been avoidable by the second proponent if for instance, they had connected first, and if their addition did not require augmentation for the earlier network state. Additionally, a third proponent may now find that adding to a network requires only standard costs because of changes induced by the second proponent.

## SUMMARY

In its current review of “energy market design in light of climate change,” the AEMC is developing a process for connecting multiple generation units to the transmission network. It is our understanding that efforts will be made to apply this framework to distribution connections also. However, details have not been worked through. The difference between connection frameworks for centralised and distributed generators is potentially an important source of competitive advantage and so remains a vital issue to be resolved.

Dealing with these connection costs is an area of considerable and complex debate. In some cases, connection costs are seen as a barrier for introducing local generation. Connection costs are seen by some as contentious in part because most energy assets were built at a time of Government owned infrastructure, with costs shared across customers and taxpayers. Given these assets are now ‘sunk’, any historical distortion of cost allocation is naturally impossible to undo. However, it is important to recognise the origins of the energy market structure, to realise that a centralised supply model dominates by virtue of historical circumstance. Perhaps what is most important today is that the process and methodology for calculating connection costs faced by all new generators connecting to distribution or transmission networks are consistent, and cognisant of the potential for distortions to occur due to information or negotiating power asymmetry.

Furthermore, issues around reliability and safety are a significant concern for network operators who are responsible for the performance of their network and who are penalised for failing to meet reliability and service standards. Addition of generation (or demand reduction) within their network and outside their scope of control can lead to risk. Valuing the change (positive or negative) that local generation (or demand management) provides for the network is difficult to determine, is location specific and has no currently available standardised method for evaluation.

In Australia, these issues are being considered via the Ministerial Council on Energy (MCE) review on “Network Incentives for Demand Side Response and Distributed Generation” and the AEMC review of “Demand Side Participation in the National Electricity Market.” A number of similar processes are underway abroad, one of the most relevant being those under taken by the Office of the Gas and Electricity Markets (Ofgem) in the United Kingdom (see Ofgem, 2009).

## 2.7 Enabling large scale uptake of distributed energy

Realising the value of distributed energy in an efficient way depends on many conditions being met, not just an effective integration of generation and the network. To inform our understanding of these issues we conducted a series of stakeholder interviews and undertook a meta literature review of perceived barriers to distributed energy. We also conducted distributed energy case studies, and used insights gathered from social science conducted for this project and related work.

Indicatively, based on interviews with 47 industry and Government stakeholders, research conducted by CSIRO (2009) suggests a hierarchy of conditions that need to be met before distributed energy achieves wide scale uptake. The following hierarchy is adopted from the report:

- Distributed energy needs to be a commercially viable alternative to mains grid supply before it will have widespread uptake
- For distributed energy to be commercially viable, policy and regulation needs to allow proponents to capture the value of distributed energy where it reduces emissions or costs that are otherwise socialised - primarily seen as costs of peak demand infrastructure
- Policy and regulation must also have long term certainty to give distributed energy proponents and investors the confidence to implement distributed energy
- Consumers, industry and governments all need to be educated on the value of distributed energy and how it works to overcome cultural bias towards mains grid energy supply. This is also needed to inform appropriate policy and regulation development
- Technology and market development needs to be focussed on reducing cost and improving reliability.

A literature review of barrier studies broadly corroborated these findings and allowed a more fine grain understanding of issues to evolve. From these findings, a summary of key enablers (outcomes which should lead to an efficient deployment of distributed energy technologies and systems) were developed. They are as follows:

- A long term policy horizon with firm targets and commitments for uptake of distributed energy that have widespread support across the political spectrum. Implicitly, that distributed energy is a highly visible and important policy deliverable, and that the market has improved certainty about how distributed energy is valued
- Data that allows more accurate valuation of different forms of distributed energy incorporating real time market costs and a full suite of environmental and social externalities
- The use of a widely accepted, accurate, transparent, efficient and equitable distributed energy valuation methodology across government agencies when developing distributed

## SUMMARY

energy related policies, programs and regulation including building standards, appliance standards, product rebates, feed in tariffs and so on

- Accurate, transparent pricing methodologies, accounting for time and location specific environmental and social externalities, for energy exported by DG and/or when DG is used for demand management that allows value to be easily captured by a full range of market participants (small to large, with various technologies)
- Full and efficient access to markets for services provided by distributed generation including the ability to easily aggregate small generating or load reduction units into wholesale markets
- A regulatory and policy framework and environment that effectively aligns the incentive of companies in the supply chain, or encourages business model innovation, to provide efficient energy services to consumers, including conducting research, trials, and continued innovation. These incentives must be compatible with market competition, have broad support, be well understood and followed
- An efficient, transparent process for connecting distributed generators, standardised as far as possible and coupled with effective low cost dispute resolution. Processes are needed for connecting multiple units and aggregating the costs based on aggregate impacts of connections
- A well informed, trained/accredited, skilled workforce that understands the value of distributed energy and can sell its benefits to consumers of all types using insights provided by decision making science
- Improved information provision and framing of costs and benefits to consumers to allow easy and accurate valuations of distributed energy options
- Tax, rebate and/or financing schemes that enable widespread access to cost effective distributed energy that would otherwise not be taken up due to high capital costs or lack of access to capital. That this be done by providing efficient, easily recoverable financial incentives and reframing decision making biases (sticky budgets, incorrect weighting of probable outcomes, inefficiently high hurdle rates). This includes access to assistance for low income and small business market segments
- A comprehensive research and development program that allows for overcoming technology lock-in at a scale in line with the need for efficient uptake of distributed energy and complementary policies/programs structured to move technologies efficiently through their development lifecycle
- A system of State and local planning and environmental controls that allows for a full consideration of issues, and ensures distributed energy is not blocked without robust justification
- Education of relevant service sectors (designers, architects, engineers, builders, tradespeople, manufacturers) on the value of distributed energy, and methods for better aligning their service incentives with long term, efficient supply of energy
- Continued and bolstered support for minimum performance standards (appliances, buildings), improved information provision (future energy prices, probable savings over time etc)

- Targeted, efficient incentives for landlords – structures for recovering cost savings from energy efficiency. Minimum efficiency standards can be stretched for the more expensive end of products/services
- Effective education around smart meters, tariff structures, how best to manage energy, processes that provide real time feedback and rewards (internal and external) to customers for effective behaviour
- A policy and regulatory environment where experimentation can take place, but where best practice is quickly adopted consistently across the nation.

It is important to note that many of these enablers are either in place, or being worked towards by current and ongoing policy, regulatory, commercial and academic processes. These enablers should not be seen as a list of outcomes that either have not, or will not be achieved. Rather they can serve as a checklist for policy makers, regulators, industry and researchers to guide their actions as the market for distributed energy evolves.

It is important to note that due to the disaggregated centralised energy supply chain in Australia, no one business in this supply chain can capture the full value of distributed energy. This acts to dilute the incentive to invest, and has the potential to result in significant investments that do not achieve socially efficient energy supply. How this can be best overcome is not simple, but ultimately, enabling distributed energy is likely to require the bringing together of many complementary policies. Split incentives, access to finance, renewable energy policies, energy prices, skill and industry capacity, from architects, through to builders and trades people, can all impact on the uptake of distributed energy and must be addressed simultaneously.

## 2.8 Distributed energy and policy making

It is clear that policy outcomes are critical to the transformation of industry, in this case the energy industry. The policy development process is highly mediated by diverse stakeholder interests. The relationship between policy decision makers and the various layers that seek to influence them is a complex dynamic. The policy making process occurs at State and Federal levels, sometimes with significant overlap. Policy making and the programs, instruments, environmental and planning controls that come out of policy decisions are in a constant state of flux.

An analysis of policies and programs related to distributed energy shows the uptake of distributed energy sometimes overlaps and competes within or between jurisdictions. There is sometimes uncertainty over the longevity of programs, which can make it difficult to map the framework comprehensively, but more importantly, may make it difficult for those trying to implement distributed energy to plan their activities.

For this reason, rather than policy outcomes, we see the process of policy making as critical to realising the value of distributed energy, recognising this is an emerging market and that it takes time for the new institutional relationships required to realise the value of distributed energy to evolve.

Best practice policy making is the subject of considerable research and attention. Evidence based policy making is an approach that ‘helps people make well informed decisions about policies, programmes and projects by putting the best available evidence from research at the heart of policy development and implementation’ (Davies, 2004). Explicitly, it aims to avoid the use of ‘best hunches’ and ‘educated guesses’ in the policy development process.

Evidence based policy making includes the use of various research and analytical methods to test economic, scientific, environmental or ethical considerations to be considered in the policy making process. It can be used to identify issues to be addressed by policy makers and to guide the design of policy interventions.

Evidence based policy development has an intuitive logic, but implementing it is not always easy. Research by Campbell et al. (2007) in the UK point to issues such as the demands of political cycles, inadequate resources and political culture that can undermine the use of evidence based research in policy development. In the United States, research by Allison, 2005, has highlighted the importance of policy networks in shaping public policy relating to distributed generation. Ostrom et al. (1990) in Allison (2005) state that:

*“Policy networks coordinate public and private actors who are increasingly bound by shared values, common discourse and dense exchanges of information...”*

In this way, policy networks can be used to overcome some of the difficulties of implementing evidence based policy development by ensuring a degree of continuity across political cycles and by encouraging sharing of resources and collaboration across institutions.

With relevance to distributed energy specifically, Research by Haas et al. (2004) and Allen et al. (2008), reinforce the need for complementary and targeted policies that can help emerging technologies develop through their lifecycle from immaturity to broad market uptake. This



requires specific policies depending on the stage of technology development. and as the technology matures through a standard S curve from research and development through to commercial deployment. Specifically, technologies first require R&D support, subsidies that allow them to be demonstrated and deployed while pre commercial, limited support as their commercial uptake is increased and finally competition policies that help drive down their costs as they are deployed at commercial scale.

In designing markets, policy interventions and/or regulatory change, it is important to consider decision making complexity. Research into decision making highlights the limitation of assuming information is processed rationally, and that decision makers will act in their best financial interest. For instance, decision making can be affected by internal (values, beliefs, etc.) and external (social norms, financial rewards, etc.) factors, and also in more subtle ways such as the way information is presented, who presents it, the ordering of words, the choice of words with only superficial differences in meaning, or whether information is provided to groups or individuals.

Because of this, research has challenged the legitimacy of traditional cost benefit analysis (CBA) in establishing the need for policy intervention, as well as the design of the policy intervention itself, recognising that decision making is often subject to anomalies. Relying on rational CBA theory to guide environmental policy only makes sense if citizens make, or act as if they make, consistent and systematic choices toward both certain and risky events (Friedman and Savage (1948) in Hanley et al., 2005).

From a policy perspective, the most important finding from Hanley (2005) is that there is potential for analytical bias to influence the interpretation of results of cost benefit analysis. Consequently, there is the potential for these biases to under or over value policy intervention and so distort the efficacy of policy design.

To overcome the potential for bias to distort efficient policy interventions, multi-criteria decision making analysis (MCDA) can be used. MCDA allows sharing of data, concepts and opinions across those involved in the policy making process including members of the public, consultants, policy agencies, and elected officials. Through iteration and reflection, MCDA allows sources of decision making anomalies such as incomplete information, misallocation of risk, or the framing of problems to be worked through and resolved (Kiker et al., 2005).

Essentially, MCDA allows a CBA to occur, but has inbuilt processes to ensure the analysis has legitimacy from objective and subjective viewpoints. MCDA is broadly consistent with the idea of policy networks discussed previously in that a well functioning policy network can facilitate the MCDA process. To an extent, work presented in this report reflects this process where insights from engineering, economics, social science and other disciplines have been incorporated to develop a more comprehensive view on the value of distributed energy.

## 2.9 Decision making, consumers and distributed energy

In ensuring efficient levels of distributed energy, one of the complexities policy makers must manage is determining when distributed energy is socially efficient, considering full lifecycle inputs and outputs. This is an inherently difficult task and there is a complex trade off between the cost and benefit of a policy or regulatory intervention to ensure a socially efficient decision occurs. Original CSIRO modelling in this report goes some way to informing efficient levels of distributed energy considering social and economic factors, and a range of environmental externalities. In a sense, this creates an upper bound to the quantity of distributed energy that could emerge should all decision makers act rationally.

While modelling presented at this stage does not capture the full complexity of time and location specific conditions that affect the value of distributed energy, it helps inform an aggregated view on what an efficient level of distributed energy may look like. Our work on this is evolving to incorporate fine grain detail including weather conditions, network constraints and social preferences with the potential to develop powerful decision making tools for government, industry and the community alike.

To a degree, the ability to realise the value of distributed energy is affected by the nature of decision making at many levels. Consumers, energy companies, policy makers, regulators and others all make decisions that fundamentally impact on the uptake of distributed energy. Each individual or group of decision makers faces distinct conditions that affect their decision making. At the customer level, implementing distributed energy where it is socially efficient requires the ability to understand and process a large amount of information relating to real time energy prices, location specific network and emission constraints, their expected energy consumption demand, the cost of implementing distributed energy and even changes to energy prices in the future that may affect expected returns. In theory, efficient price signals would enable efficient decisions about distributed energy. However as described previously, individuals do not systematically process information in a rational way.

As well as informing policy development, insights from decision making science can be used to increase the uptake of distributed energy more directly by affecting consumer decision making and aligning incentives towards a particular objective. For instance, regulatory intervention in appliance markets is driven by the recognition that competitive markets do not have sufficient incentive to improve efficiency of appliance performance over time. Essentially, it is a split incentive problem where action taken by one party has benefits that cannot be captured by that party. Regulatory intervention can essentially be two fold – standards for energy efficiency or better information provided to consumers at the point of sale. Decision making science can inform the latter option.

In strictly rational terms, it shouldn't matter whether a customer receives financial savings at the time of purchase, or over time, so long as the net present value of each option is equal. However insights from behavioural economics indicate decision making is influenced not just by the quantity of gain or loss that can be made from a decision, but by the certainty of gain or loss (Kahneman and Tversky, 1981). Decision makers can also show a preference for avoiding loss, as opposed to seeking gain (Tversky and Kahneman, 1986). In the case of energy efficiency,

potential gains from reduced operating costs over time are uncertain<sup>1</sup> while the cost of the more efficient appliance is certain. So a consumer is likely to prioritise minimising the certain loss, as opposed to maximising the uncertain potential gain. In addition, as noted previously, there are real limits to the extent to which an individual can understand the full lifecycle impacts of decisions they make. In essence, consumers act with bounded rationality.

Achieving energy efficiency is also subject to the split incentive involving landlords and tenants, where neither landlord nor tenant can capture sufficient value from investing in more efficient appliances (where the tenant pays the energy bill), or changing consumption behaviour (where the landlord pays the energy bill).

Simplistically, incentives will not be aligned where one party cannot capture the benefit of their action, or do not perceive that the benefit of their action will accrue to them sufficiently to justify that action. Aligning incentives is therefore a function of payment arrangements, but also the certainty of those arrangements. For instance, a landlord may not upgrade the efficiency of their property from 3 star to 6 star, to the extent they are unsure whether they will realise the benefits through higher rent, as opposed to whether or not they can increase rent.

Perhaps due to the complexity of this issue, the split incentive problem has not been readily addressed in many jurisdictions around the world. Regulating building standards and requiring building information disclosure are two common regulatory approaches to addressing the landlord/tenant split incentive; however this does not strictly align incentives.

Our understanding of the full complexity of decision making is still evolving, and the limitations of the rational utility maximising customer are further challenged by social science. These insights are particularly important when considering how to motivate decisions that incorporate some element that can't be, or are difficult to monetize.

In earlier work, Gardner and Ashworth (2007) developed a framework for the societal acceptance of the Intelligent Grid (see Figure 2.11). An underlying premise of the framework is that people's values, attitudes and beliefs will drive their intentions, subsequent action and eventual long-term acceptance of distributed energy and reductions in consumption. Although a wide array of psychological research supports this central premise, it is important to acknowledge that people's decisions are made within a broader context, where a range of external influences also have an impact. These external influences include economic factors and the costs of implementing distributed energy; physical/technological factors, such as the development of and access to technology; and societal factors, such as community support for low emission technology, government incentives and industry reactions. The impact of societal factors on the adoption of distributed energy is particularly relevant, since some distributed energy technology is likely to be implemented at the community level, rather than in individual households (Gardner and Ashworth, 2007). This model is described below:

---

<sup>1</sup> The consumer would need to calculate the amount of energy used by the appliance over time, the price they pay for energy and any potential future change to this price, and the operating lifetime of the appliance. They still then have to weigh up the time taken to pay off their investment against any other spending they may value (i.e. opportunity cost).

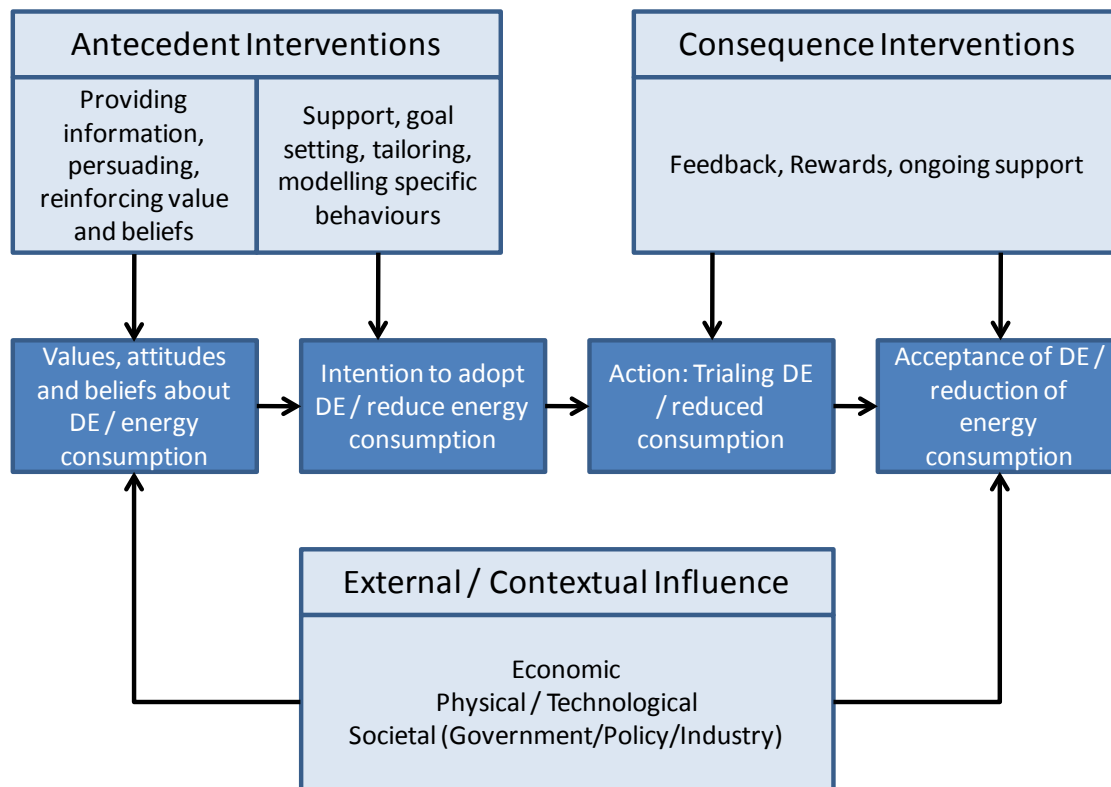

Figure 2.11: A conceptual framework for the Intelligent Grid

To develop a sense of demographic variables that affect the uptake of distributed energy, a survey was conducted across four states of Australia. The initial survey was developed with reference to psychological theory of environmental concern (Fransson and Garling, 1999; Xiao and Dunlap, 2007) and consumer technology adoption (Davis, 1989; Rogers, 1995). The survey was pilot tested in focus groups with members of the general public. As a result of this feedback some adjustments were made to improve readability and clarity. To reduce the length of the survey, two different versions were produced. One version included questions relating to demand management, and the alternate version included questions relating to DG.

Overall the survey contained four sections:

**Section One:** assessed knowledge and beliefs about energy sources and environmental issues

**Section Two:** assessed household energy use

**Section Three:** assessed reactions to local energy generation (in one version) and demand management (in the other version)

**Section Four:** assessed demographic details about the individual and their household

At the individual and household level, we find education, income levels, household size and age were most commonly the most powerful demographic variables affecting: intention to reduce electricity consumption; acceptance of demand management technology and acceptance of DG technology. Specifically, those with higher levels of education, higher incomes, smaller

household size and of lower age reported higher levels of intent to reduce consumption, accept demand management and accept distributed generation.

Where individuals report positive beliefs about environmental protection, preference environmental over economic outcomes, positive attitudes towards reducing energy consumption and perceive positive norms about reducing consumption, they typically report higher intentions to reduce energy consumption and adopt demand management and distributed generation technologies. The only counter intuitive finding was that knowledge of energy and the environment sometimes polarised people's attitudes towards reducing consumption.

Distributed energy also has important applications for large commercial applications. Based on research conducted for this report, Australian organisations most likely to adopt demand management or distributed generation technology are relatively large, and so have large energy consumption. However many small businesses also appear likely to adopt distributed energy. Therefore targeting large energy users may help maximise the impact of distributed energy, but the distributed energy market is not likely to be limited to large energy users. While financial payback periods have some influence on organisational decision making, safety, efficiency and reliability were typically the most important features of demand management and distributed generation technology.

## 2.10 Distributed energy business models

There is a natural interplay between business models for the delivery of energy and the ability to align consumer decision making with efficient energy service outcomes. A business that can capture the full value of social and environmental externalities associated with energy consumption and production has naturally aligned incentives to deliver private and socially efficient levels of distributed energy.

A relatively successful example of directly aligning the incentives across a range of functions that affect energy outcomes often referred to is the Woking Borough Council (WBC) energy service company model in the U.K. In this model, WBC sought to accelerate emission reductions in its jurisdiction through setting up a Special Purpose Vehicle (SPV) called Thameswey Ltd in 1999. The company's purpose was to form public/private partnerships to deliver projects targeting the Council's broader climate change strategy, including providing clean energy, tackling fuel poverty, water security, waste minimisation and clean transport. Generated revenues are channelled back to the council to reinvest in specific projects, such as improvements to housing, retrofitting solar PV and heating systems for low income families (WBC, 2009). By 2006, WBC had achieved 33% energy efficiency and 21% emissions reduction on residential property, against a 1991 benchmark (Resource Smart, 2008).

The success of the model is that it aligns environment, social and economic objectives, delivered through a single entity that can capture the full benefit of its action either directly through revenue recovery, or indirectly through socialised value it provides to the community. Significantly, the vehicle is also empowered to deploy a full suite of distributed energy options and is resourced with the necessary technical capability. The entity also aligns incentives that are often weakened due to disaggregation between generators, network companies and retailers, and the regulatory and market structures within which they operate.

In this way, WBC was able to overcome many overlapping and related barriers that typically impede a wide range of distributed energy options. The business model also allows a number of key enablers identified in this chapter to be realised because it does not have to directly recover the value of social and environmental externalities that it reduces, as the value is spread across the community.

Ultimately, it is likely to be a policy choice whether such a business model can be deliberately constructed by Government jurisdictions in Australia, for example by local governments, or whether through policy, market settings and regulation, such models are encouraged for others to develop and implement.

Another model for maximising the uptake of distributed energy where it is efficient includes community collaborations. The Maine's Power project was initiated by a local community and environment group (Mount Alexander Sustainability Group; MASG) who discussed the project concept with the four businesses (referred to within as Sites 1-4). With the help of representatives from the CSIRO Sustainable Communities Initiative (SCI), MASG gathered together external expertise and facilitated external funding through government funding agencies. The businesses and other project participants discussed an ambitious goal of 30% greenhouse gas reductions by 2010. This was selected based on what the businesses believed they could achieve, and to match the same target set by the local council.

The project was developed as a non legal partnership model to enable four businesses to work together with government agencies, peak industry bodies, energy retailers, distribution network owner operators and environmental organisations to achieve an ambitious 30 per cent reduction in greenhouse gas emissions by 2010.

This partnership model was advantageous in two ways. First, it helped facilitate and guide business decisions, particularly for those businesses not directly employing an energy and operation specialist. While energy costs may be significant to most businesses, in general the cost is considerably smaller than other processes such as labour and material costs. Second, the partnership model allows government agencies to continue their skill development, to retain information learnt, and to collate and pass on relevant knowledge to businesses and the community in the future.

In consultation with CSIRO, MASG developed a general project plan based on a three stage approach. The first stage was to analyse the energy landscape of the local region and more specifically for the four businesses. The second stage was the identification of options to meet the project reduction goals knowing the energy use patterns.

During the first stage, a project partner was identified to undertake energy efficiency audits as an in-kind contribution. Unfortunately, the partner moved from their business and their in-kind contribution was not able to be filled by remaining participants. In response, the businesses were asked to pay for an external audit of their sites (with financial assistance from SV) by an accredited company. It was thought appropriate that each business contributed financially to this task in the belief it was something they should undertake as part of their normal operations.

Given the timelines of the audit process it is recommended that this action is taken at the very beginning of the project and is preferably carried out by an external party unless contingencies are available for those contributing on an in-kind basis. This allows both a thorough understanding of the business operations and energy landscape as well as a more considered project goal to be established.

While the energy audits are vital, it should be noted that the process only informs action but does not ensure action is carried out. For example it was found one of the businesses had undertaken an audit in 1998 as part of the Federal Government greenhouse gas challenge with little action taken as a result. The partnership model undertaken in this study can help facilitate information exchange and dialogue which can increase the chance of implementing audit recommendations.

Surveys were also conducted at the beginning of the work program to establish the perceptions, understandings and goals of the diverse group of participants in the study. A number of interviewees expressed a wish that the solutions proposed included new and innovative ideas. In general, these innovations were considered primarily in a technological sense.

The surveys revealed that when attributing their funds to projects Government agencies aim to encourage the uptake of technologies or policies they believe have merit for their core agency values. In this case, the agencies involved were primarily driven by the environment and rural community development. Second, the agencies provide funds in the hope of developing new and novel ways of dealing with often common problems.

## SUMMARY

The businesses surveyed had interest in the project for similar reasons, those being an interest in improving their environmental performance and in fostering ties with the community. While the public sector may contribute funds to the development of innovative solutions, it is the businesses that bear the greatest financial impost and risk when adopting change in their operation. This is not an unreasonable position as it is the businesses who gain from efficiency improvements.

In a sense, the public sector can be a vital source of information, skills and sometimes funds to ensure that changes to the business as usual approach can be tackled with minimal risk. The partnership model used in this project provides an excellent structure to improve project outcomes for future community driven projects. While technologies may play a significant role in innovation, there are potentially more gains to be had in developing new business and engagement models that allow risk and gains to be spread across all participants. Ultimately this is needed to overcome reluctance to deploy technology.

The project highlighted that the local network businesses are vital stakeholders when trying to reduce consumption in the stationary energy sector. It is their asset base which allows the flow of energy and it is their asset in which local generation or demand reduction activities may be located. Network businesses are highly regulated and subject to severe penalties when their service falls below specified standards. As such, these businesses have a propensity to adopt well understood practices, as opposed to continually innovate, to ensure their business operates within regulated guidelines. However new regulatory incentives are helping to change this.

For example, an energy recovery method for reducing high transient loads in the local network was identified as a potential project for Site 2. Figure 2.12 displays an example of the large intermittent peaks from this business. Realisation of this method would involve Powercor (the local DNSP) taking a risk based on the engineering knowledge, skills and information provided by Site 2 staff. If Powercor were to take this risk, they would need to retrain their staff or buy in the services of Site 2 personnel to ensure the system was well maintained and operated within regulatory requirements. However the recently proposed demand management Incentive Scheme (DMIS) by the Australian Energy Regulator (AER) provides a means for Powercor to consider trialling this option as a new and innovative technique to reducing the largest single source of transient peaks in the local network. While the adaptation of the technology used in this scenario is somewhat innovative (similar systems are used elsewhere such as in desalination plants for instance), the real innovation comes from changing business processes.

An alternative method for potentially alleviating peak load issues from Site 2 caused by equipment testing was also considered in discussion with the other project partners. At Site 1, large cold stores that have a high thermal inertia are used. The business could install simple switch gear that could coordinate a demand response that minimises network demand during the start-up of Site 2 tests by switching off compressors to the refrigeration system. This application could be used for small periods of time (say 10s of minutes) at minimal cost and with minimal disruption to Site 1 activities. Again, the innovation could only be realised through the partnership model.



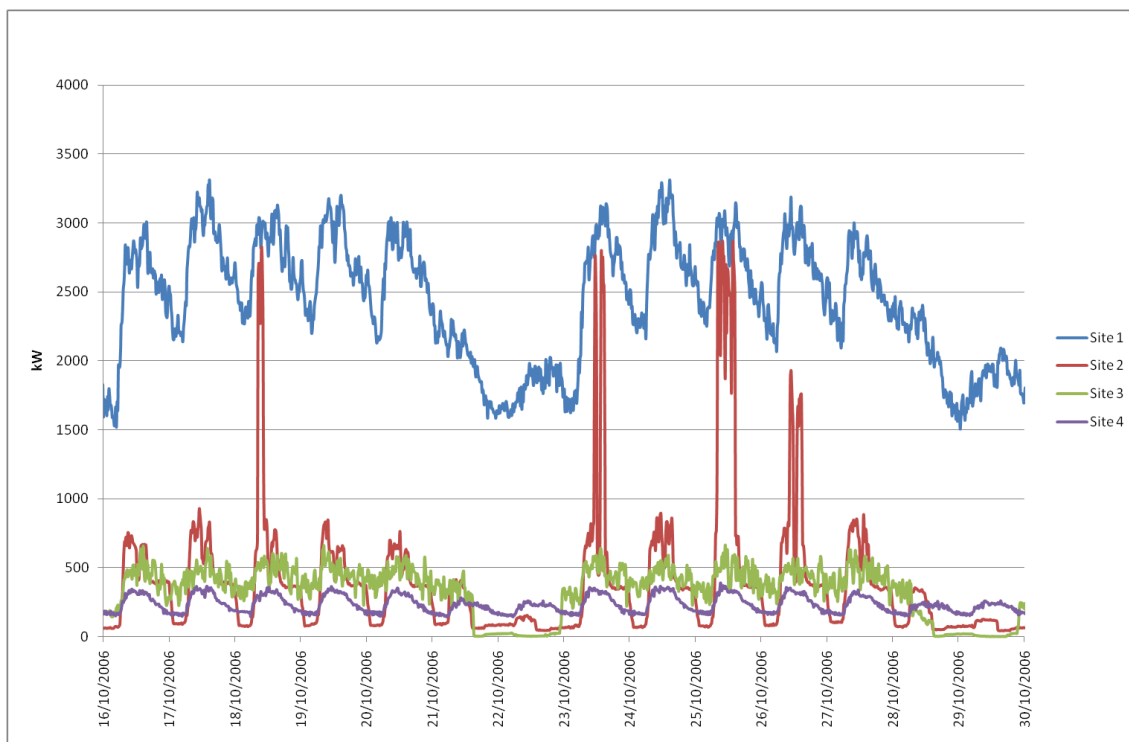

Figure 2.12: 15 minute average power (kW) consumption for a two week period in the base line year from the four businesses in the Maine's power study

## 2.11 Integrating distributed energy with energy markets

When considering business models for energy delivery, how they can effectively align incentives within the energy supply chain, and across property and appliance ownership structures, it is useful to consider commercial and institutional structures that influence Australia's energy markets.

The Australian NEM has relatively formal governance, commercial, security and technical decision making regimes. In summary, these organisations have the following roles:

- The Council of Australian Governments (COAG) brings together Federal and State governments in a forum to coordinate policy development, and set policy principles at a high level
- The Ministerial Council on Energy (MCE) coordinates Federal and State policy and has oversight for rule and regulation development
- Uniform industry-specific legislation, the National Electricity Law (NEL) defines decision-making constraints for the electricity industry including commercial, technical, security and regulatory arrangements. The specific details of these arrangements are set out in the National Electricity Rules
- The AEMC manages the National Electricity Rules, and the rule change process by which they can be further developed
- The AER enforces regulatory requirements and manages particularly regulatory processes such as the review and approval of network investment plans. It also monitors compliance with the National Electricity Rules by market participants as well assessing the overall effectiveness of these rules
- The Australian Energy Market Operator (AEMO) is both the market and system operator and thus has responsibility for implementing and managing both the security regime and the short-term aspects of the commercial regime.

The institutional and legislative framework of the NEM has been developed over many years and has been reinforced by the dominant centralised supply model. Small scale energy and demand management have fulfilled relatively niche roles and in some instances have been used to reinforce the dominance of the centralised supply model, for example, the use of off peak electric resistance hot water systems.

It is important to note there are processes underway that will enable better integration of distributed energy into the NEM, including potential rule changes to allow aggregated generation and load participation in wholesale market operations.

Design of regulation to meet environmental or social objectives and integration of this regulation with energy market operation is relatively new and integrating them with the market is not always easy. Environmental and social objectives are not always immediately compatible with business models that operate in the existing energy supply chain. For example, very generally, various sources of cost and value for solar hot water and PV may impact on different businesses in the supply chain as follows:

**Baseload generators:** could be negatively affected by solar hot water at significant levels of deployment

**Peaking generators:** could be negatively affected by PV (at significant levels of deployment) to the extent that it correlates with times of network-wide peak demand

**Network companies:** could be negatively affected by reduced energy volumes if they result in demand growth slower than forecast as part of their network investment plans. Or could benefit from PV to the extent it provides network support, reduced losses and power quality benefits that outweigh any unrecovered connection costs

**Retailers:** the net impact may vary depending on any generation assets owned, exposure to peak wholesale prices, or even levels of integration into solar PV and hot water markets.

Supply-side participants in the energy market are generally large, well resourced, focussed almost exclusively on the electricity industry and have considerable shared interests. End-users are far more diverse, typically less well resourced and may have interests beyond electricity itself. In this environment, effective representation of end-user interest in NEM Governance and broader policy decision making is a difficult process. Formal governance processes must be able to manage these asymmetries between supply and demand-side stakeholders in order to represent environmental and social interests in NEM design and operation.

Ultimately, successful introduction of any new technology into the NEM requires the effective support of these institutional decision makers as well as supporting organisational infrastructure. In the case of distributed energy, this includes not only the organisations and people directly involved with the technology such as designers, retailers, installers, but also those who have to manage the impacts of that technology on the rest of society. This support infrastructure does not automatically emerge in response to market signals and so highlights a role for government, not only in education and training but in developing the necessary institutional decision making structures. This is an important consideration for policy makers seeking to harness the value of distributed energy.

Integrating and valuing new technology, specifically distributed energy into the NEM, also requires explicit, transparent methodologies for signalling, motivating and optimising end-user participation to facilitate effective decision making. Active participation by the majority of end-users (residential and commercial) will require that the uncertain time and location varying value of energy is better reflected in the prices these end-users see, or that end users and/or third parties will be able to capture the value of distributed energy where it supplies energy services below time and location specific costs. The use of interval meters coupled with price deregulation goes some way to achieving this. However, it must be recognised price is a limited tool if used in isolation. Without access to information, financial support and potentially specialist skills to facilitate behaviour change as well as new physical infrastructure, customers may have a limited response to price signals. This decision making complexity highlights the potentially important role of energy service companies that can optimise delivery of energy services to customers.

Investment decision making is also a critical component of the NEM. Forward looking prices and planning documents can help signal where future investment are needed. For example, investment in centralised generation is largely driven by the Statement of Opportunities (SOO) report. Released by the market operator (AEMO), it details historical demand, demand

## SUMMARY

projections and projections in energy shortfalls. Efforts are being made to replicate a comparable process at a distribution network level, with distribution companies required to release network planning details and signal opportunities for demand side proponents to offer alternatives to network building. However signalling for investment in distributed energy is naturally a more complex process due to the fine grain nature of location and price signals it can be driven by, as well as the sometimes competing interests of the energy supply chain and distributed energy proponents. Furthermore, to capture a full suite of distributed energy opportunities, these decision making signals must incorporate the intersection between natural gas and electricity, a potentially significant issue given the relative immaturity of natural gas markets and the predicted impacts of natural gas based technologies.

Demand management, one important element of distributed energy, relies heavily on energy market structures to realise value. This is because it primarily operates to resolve time specific network or generation constraints. Demand management refers to a suite of technologies and techniques used to alter demand profiles over time. Active control measures can smooth or shift demand peaks, or substitute local generation for centralised generation. Passive control measures such as energy efficiency can reduce total demand over time. Figure 2.13 provides an illustrative demand profile, indicative of a network area dominated by commercial energy demand and hence a midday peak in summer. In this example, the blue curve shows demand ramping up from 6am when people begin to wake and get ready for work. Demand grows during the day peaking before lunch as air conditioning demand grows in commercial buildings. The demand then drops off slowly briefly peaking again in the late afternoon as people return home.

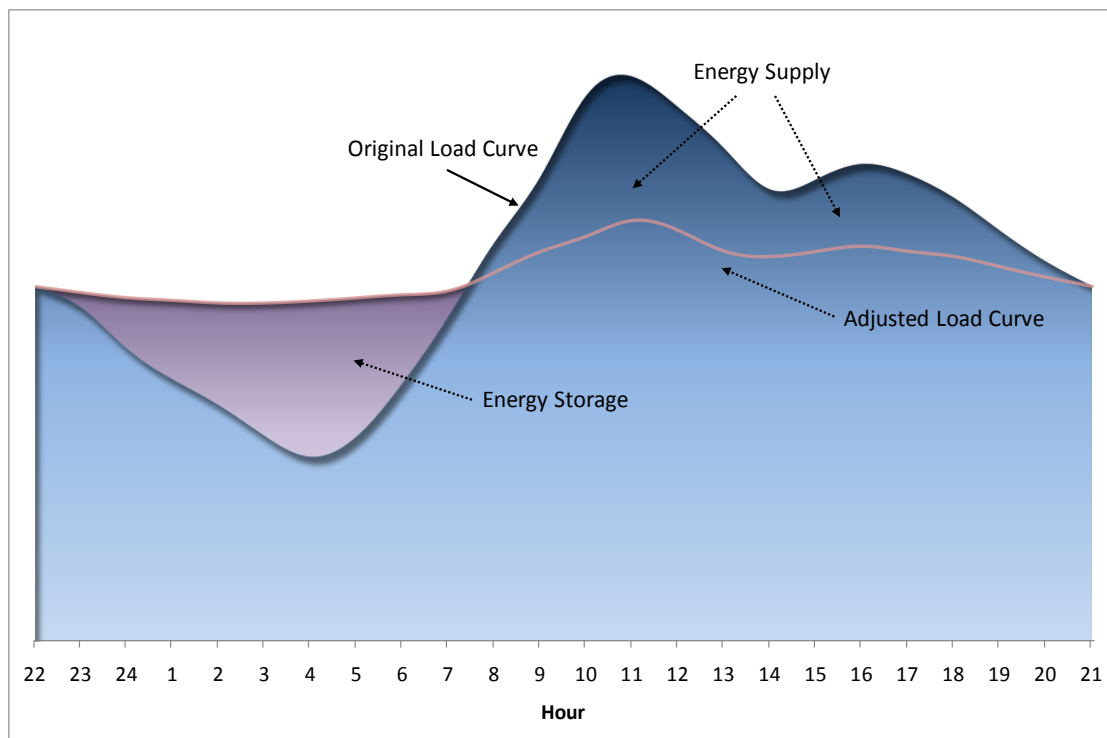

Figure 2.13: A hypothetical daily demand profile including storage

Demand management offers potential value to network companies, energy retailers, energy customers and the market operator. Most simply, it can defer spending on network assets for network companies, reduce wholesale prices particularly at peak times and reduce retailer exposure to wholesale market price volatility. However, it can also offer more complex services, for instance controlling loads in emergency situations (such as power shortages or outages), providing frequency control and ancillary services, or managing customer exposure to generation or network charges according to stated preferences. By way of example, Read et al. (1998) in Ackerman et al. (2000), found that ancillary service costs were reduced by 75% in the first year that interruptible load was allowed to participate in the New Zealand energy market.

One mechanism recently developed to facilitate demand management is the demand management incentive scheme for network businesses. In acknowledgement of the complexity facing demand side solutions, the AER have developed Demand Management Incentive Schemes (DMIS) for distribution businesses. At this stage, the DMIS in each State differs slightly to reflect State based regulation, prior to National regulation. The AER intends to deliver a national version once national policy settings such as CPRS and reviews such as AEMC's demand side participation are understood.

The objective of the DMIS is to provide incentives for DNSPs to implement efficient non-network alternatives or to manage expected demand for standard control services in some other way. It is not designed to be the primary source of funding for demand management expenditure which is based on the approved forecasts of operating and capital expenditure in the AER's determination for a particular DNSP.

The scheme will provide a demand management innovation allowance (DMIA) which allows the DNSP to recover funds allocated to these non network solutions through two mechanisms; an annual ex-ante (before the event) allowance in the form of a fixed amount of additional revenue, and a forgone revenue recovery scheme.

It is important to note that demand management led by distribution network businesses is only one model. Demand management could be performed by retailers or third parties, to the extent they can capture the value of doing so and thereby make a commercial return.

In New Zealand, demand side participation has been effectively used to manage network constraints. In November 2008, New Zealand's energy grid network management company Transpower, released a Report entitled "Demand-Side Participation (DSP) Trial 2008" detailing outcomes of a DSP trial conducted from June to August in 2008 across a limited network corridor of northern New Zealand.

Eleven organisations were interviewed as a case study for this report in order to understand their experience of the Trial, and ultimately what influences the degree to which businesses can engage in demand management in response to market signals.

Organisations interviewed generally show a high degree of satisfaction with the Trial, being able to achieve financial savings that outweighed business disruptions. They support the concept of demand side participation as a short to medium term measure for managing supply side issues. However in the long term, they indicate a preference for managing supply issues directly through building transmission network and/or generation capacity.

## SUMMARY

While some organisations were new to the concept of demand side participation, they were able to overcome initial issues by developing strategies for optimising their demand response. They highlighted a need for developing automated processes, and receiving immediate feedback on the success of their response to improve their ability to manage their demand in the future.

Financial incentives were deemed an important motivator for participation. However along with financial considerations, participants noted the importance of assurances of minimal disruption to day to day business activities and therefore the low risk participation in the Trial. Some participants indicated they were assured by the opt out clause. This meant they could ‘give the Trial a go’, but pull out if it wasn’t working for them. Related to this assurance, several organisations noted the communication structure implemented during the Trial as a contributing factor in the decision to be involved.

The majority of interviewees indicated that in the short term, DSP was a viable and effective tool for mitigating supply issues during peak periods, however that its use should be short term. Long term, DSP was not considered to provide the answer to New Zealand’s ongoing energy supply issues and it was felt it should not be used to deliberately avoid upgrading the network where this was necessary. Concern was raised in relation to placing the onus on industry for ensuring uninterrupted supply through DSP, commenting that industry should not have to “bear the brunt of poor investment decisions.”

These preferences are broadly compatible with the intended use of DSP. That is, it is not intended to replace capital expenditure on grid infrastructure, rather complement it or delay it if necessary, to ensure reliable supply at peak times until new infrastructure can be built. However the concerns raised highlight the importance of ensuring network companies, or others, do not have an incentive to use DSP as a long term, ongoing measure to avoid network building, unless the benefits of doing so outweigh the costs in the long run.

Demand management is also being used in Australia at the domestic customer level. Data from a domestic trial conducted by ENERGEX, analysed as part of this report, supported an overall conclusion that participation was primarily driven by two factors: the confidence customers had in the trial, and by the sense of community contribution and connection they associated with the trial. Those who has experience with earlier trials (continuers) reported the most confidence in the trial, and had the strongest sense of contribution and connection. Levels of confidence and sense of contribution/connection were moderate for trial newcomers, and were lowest for eligible non-participants. Positive outcomes, including positive evaluation of the trial, positive word of mouth, and intentions to participate in future trials, all tended to be higher for people with higher levels of confidence and connection/contribution. These conclusions are best represented in the illustration below (Figure 2.14).

Based on the initial qualitative data and previous research into consumer choice and decision-making, a preliminary model of potential drivers and barriers to trial participation was identified. Each major element in the model was tested in the survey.

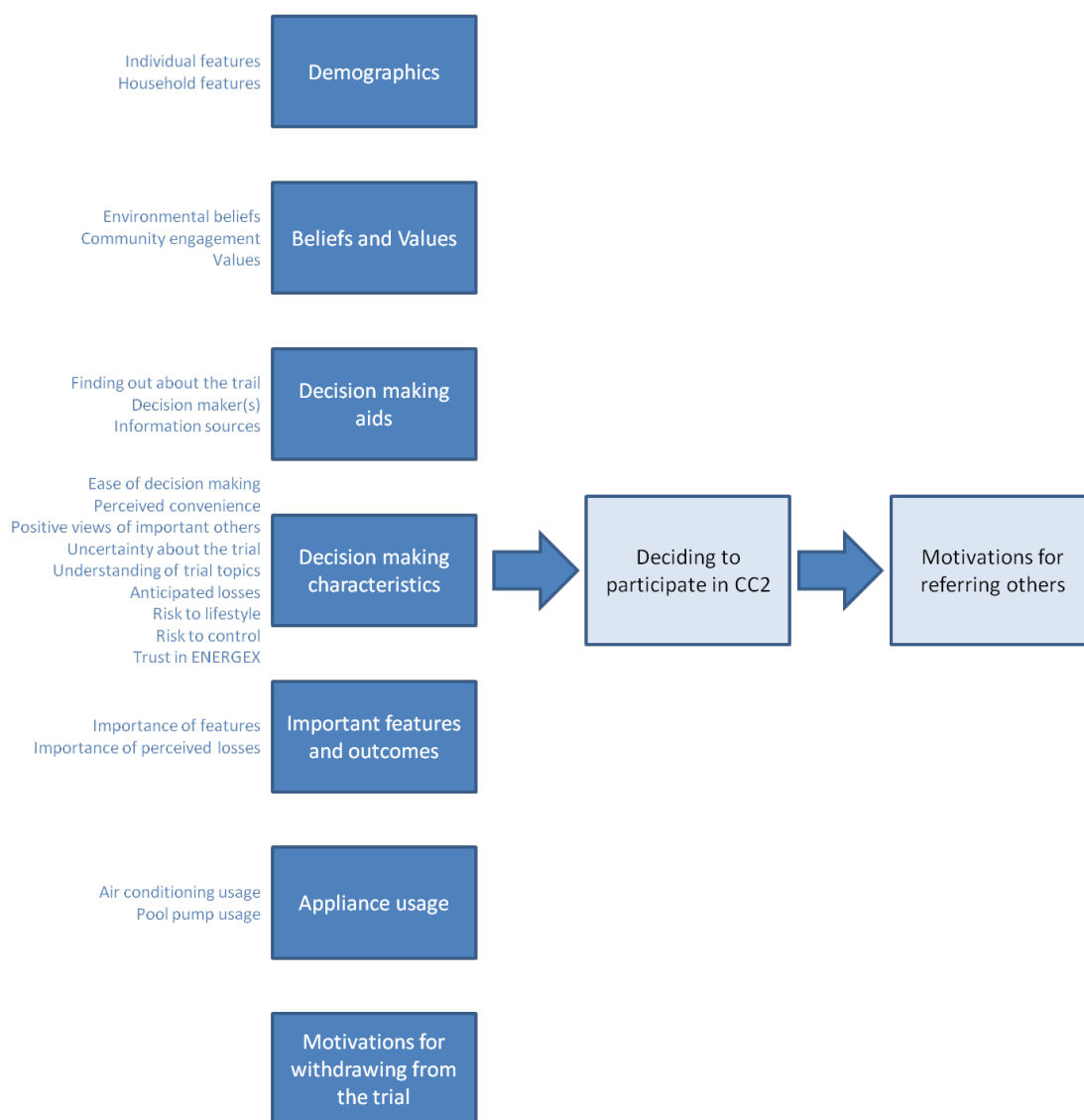

Figure 2.14: Potential barriers and drivers to participating in CC2

Positive word of mouth and supportive opinions of others in the household appear to have been very important in encouraging people to participate in the trial. This effect is consistent with previous research which shows that people are more likely to trust and accept something if it has been tried or supported by people that they know, or by people who are similar to them in some way (including living nearby). When the trial is expanded, it may be most effective to expand to neighbouring suburbs first, rather than suburbs in a completely different area, because the former will benefit more from existing awareness and from the reassurance that people similar to them are already involved.

## 2.12 Global trends in distributed energy

It is difficult to make global comparisons about distributed energy penetration due to the wide range of variables that affect its uptake including: availability and cost of centralised energy; geographic characteristics; climate; population density; energy market structure; economic structure; policy; and regulation. However it is reasonable to assume the market for distributed energy in Australia will be affected by global trends, as technology development and new system design configurations overseas will influence technology and system development in Australia.

Distributed energy can be deployed anywhere thermal energy or electrical power is needed. Figure 2.15 from the World Survey of Decentralised Energy (WADE, 2006), illustrates the extent to which DG is deployed (at 2006) in various countries.

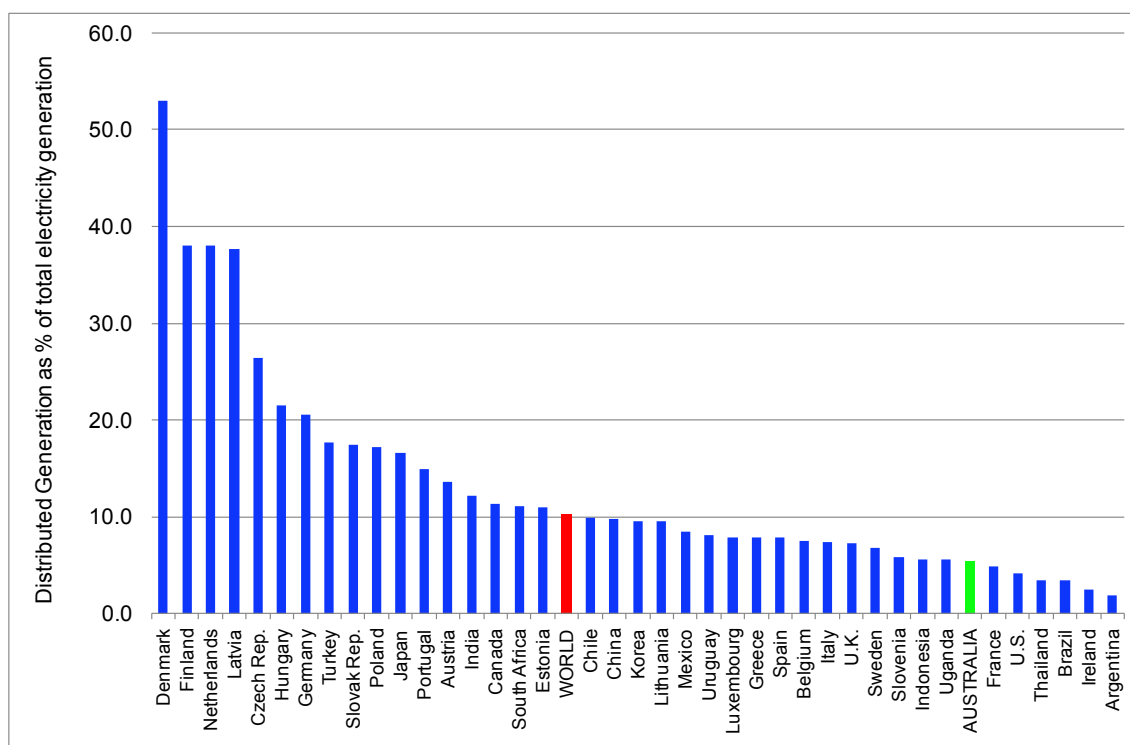

Figure 2.15: Proportion of electricity from DG (WADE, 2006). Reproduced with permission from WADE

Evident from this figure is the below average deployment of distributed energy in Australia when compared to the world average. Generally speaking, countries with high proportions of distributed energy tend to have the following characteristics:

- Relatively cold climates
- Highly urbanised, densely populated cities
- Industrial sectors that account for a large share of economic activity
- Concerns over energy supply security and fuel scarcity, and
- Focused government policy on electricity and heat supply.



European countries generally have greater proportions of distributed energy than other countries, primarily due to the above criteria. However various distributed energy applications are suited for both industrialised countries and emerging economies. The flexibility of distributed energy as a power source is perhaps highlighted by the penetration of distributed energy in China and India being approximately average by global standards, despite having significantly different economic structures to high ranking countries.

Although the United States has relatively low levels of distributed energy, energy security concerns and a changing political landscape for renewable energy, is likely to drive an increase in distributed energy, enabled by smart grids.

For Australia, the experience around the world suggests there may be considerable untapped distributed energy potential, most probably constrained historically by the low cost and abundance of centralised energy supply and Australia's climatic conditions. However, with many of Australia's centralised supply infrastructure assets either in need of, or in the process of renewal, growing recognition of the importance of greenhouse gas pollution reductions and technological development that allows the use of heat for cooling, Australia is well positioned to increase its penetration of distributed energy and secure the benefits it can provide.

When compared to nations of comparable economic development, China and India are two countries with relatively high levels of DG by global standards. They share similar economic, demographic and geographic characteristics with large rural populations, fast growing urbanised populations, rapid industrialisation and a range of renewable energy resources, albeit not yet fully developed. Both countries are using targeted programs to electrify rural areas and improve access to other forms of energy in remote areas including heating and lighting, which may be conducive to distributed energy.

Table 2.4 shows that in 2006, around 70% of Indian electricity production came from coal, with 15% from hydro and 8% natural gas. Wind, solar, and biomass energy make up less than 2% of all electricity generation.

SUMMARY

Table 2.4: Electricity production sources in India (IEA, 2009a)

INDIA	Energy Production (GWh)	Technology Mix (%)
Production from:		
- coal	508,362	68%
- oil	31,475	4%
- natural gas	62,092	8%
- biomass	1,930	0%
- waste	0	0%
- nuclear	18,607	3%
- hydro*	113,599	15%
- geothermal	0	0%
- solar PV	19	0%
- solar thermal	0	0%
- wind	7,994	1%
- tide	0	0%
- other sources	0	0%
Total Production	744,078	

Table 2.5 shows that China has a similar energy production profile to India with 80% coming from coal, 15% from hydro, and the remained primarily from oil and nuclear. Almost all of its biomass energy is used in residential applications, most probably in rural communities. As shown below, this is not yet a significant source of energy in China.

Table 2.5: Electricity production sources in China (IEA, 2009b)

CHINA	Energy Production (GWh)	Technology Mix (%)
Production from:		
- coal	2,301,402	80%
- oil	51,469	2%
- gas	14,217	0%
- biomass	2,514	0%
- waste	0	0%
- nuclear	54,843	2%
- hydro*	435,786	15%
- geothermal	0	0%
- solar PV	105	0%
- solar thermal	0	0%
- wind	3,868	0%
- tide	0	0%
- other sources	0	0%
Total Production	2,864,204	

However the quantity of installed renewable energy is expected to significantly change in China over the next decade. The Government has established targets for the development of various sources of renewable energy up to 2020, requiring 10% of total energy consumption by 2010 and 15% by 2020 to be renewable. An investment of ¥CNY 2 trillion (approximately \$US 263 billion) before 2020 on renewable energy development in China is envisaged to reach this goal. By 2020, the plan calls for the development of a total of (IEA, 2009c):

- 300,000 MW of hydropower
- 30,000 MW of wind power
- 30,000 MW of biomass
- 1,800 MW of solar power
- 300 million m<sup>2</sup> coverage of solar hot water heaters
- 44 billion m<sup>3</sup> of methane gas per year
- 50 million tonnes of biofuel.

Table 2.6 details the current penetration of different forms of energy within India, including distributed and decentralised systems. In total 14,224 MW of grid interactive renewable power capacity was installed at the end of January 2009 representing around 10% of total installed generation.

Table 2.6: Current installations of renewable and distributed energy sources in India (MNRE, 2009)

Sources / Systems	Cumulative capacity (as of 31.01.2009)
<b>Grid-interactive renewable power</b>	
Biomass Power (Agro residues)	683.30 MW
Wind Power	9755.85 MW
Small Hydro Power (up to 25 MW)	2344.67 MW
Cogeneration-bagasse	1033.73 MW
Waste to Energy	58.91 MW
Solar Power	2.12 MW
<b>Off-grid/Distributed Renewable Power (including Captive/CHP plants)</b>	
Biomass Power / Cogen.(non-bagasse)	150.92 MW
Biomass Gasifier	160.31 MWeq
Waste-to- Energy	31.06 MWeq
Solar PV Power Plants and Street Lights	3.00 MWp
Aero-Generators/Hybrid Systems	0.89 MW
<b>Decentralized Energy Systems</b>	
Family Type Biogas Plants	4,090,000
Home Lighting Systems	434,692
Solar Lanterns	697,419
Solar PV Pumps	7,148
Solar Water Heating - Collector Area	2,600,000 m <sup>2</sup>
Solar Cookers	637,000
Wind Pumps	1,347

Note : MW = Megawatt  
MWeq = Megawatt equivalent  
MEp = Megawatt peak

Their experience points to the significant potential for distributed energy where there is a relative lack of centralised supply infrastructure. This is because distributed energy is often low cost, modular, and renewable, making it a logical choice particularly where centralised alternatives have not yet been developed. The importance of highlighting their experience is because trends for distributed energy in Australia or globally, may largely depend on innovations developed for specific regions of the world. It is reasonable to suggest that as China and India manufacture distributed energy solutions for large scale deployments in their own regions, this could have significant impacts on the cost of distributed energy solutions globally.

## 2.13 Distributed energy in Australia

Many of Australia's centralised supply infrastructure assets are either in need, or in the process of renewal. Combined with growing recognition of the importance of reducing greenhouse gas pollution, emission intensive centralised generation will become increasingly more expensive. With technological development that allows the use of heat for cooling, well suited to the Australian climate, Australia is well positioned to increase its penetration of distributed energy as an alternative to centralised generation.

Australia's energy supply system was developed at a time when large scale, centralised generation plant close to fossil fuel resources, was the optimal supply model. It allowed economies of scale, and took advantage of the relative efficiency of transporting electricity, as opposed to transporting coal or gas.

Today, the imperative to address climate change and technological change is challenging the dominance of this central supply model. Small scale generation close to load creates significant efficiencies, allowing for the useful recovery of heat, otherwise wasted in the generation of electricity. It can reduce electrical losses on transmission and distribution network infrastructure, particularly in rural areas and can improve power quality while imposing minimal additional costs and risks to network assets.

Advances in emerging technologies such as solar photovoltaics has the potential to make clean energy generation at the point of consumption viable with grid supplied electricity. Advances in communications and control devices has the potential to facilitate smart grids, where the supply and consumption of energy can be seamlessly optimised, maximising the potential to integrate clean renewable energy generation with grid infrastructure. Combined with building design optimisation and efficient heating and cooling systems, distributed energy systems are currently reducing, and offer significant potential to reduce greenhouse gas emissions cost effectively in the future.

This new energy supply model, with decentralised generation, decentralised decision making, and active consumer input has the potential to create highly resilient energy supply systems, reducing the cost of high impact, low probability events such as power outages caused by bushfires. Naturally this type of resilience comes at a cost, requiring network islanding and sophisticated control systems. As climate change heightens the risk of extreme weather events such as bush fire and high wind speeds, decentralised energy supply models may offer significant risk mitigation value, by removing the reliance on vulnerable transmission and distribution infrastructure. While detailed modelling of costs and benefits of this type of supply model have not been undertaken here, it may be a field of future research.

This imperative of transitioning to a decentralised energy supply model is heightened by the need to mitigate the risk of clean central supply technologies failing to emerge from concept to reality, highlighted by economic modelling work which shows distributed energy playing an even greater role in emission reductions should carbon capture and storage technology not evolve.

A distributed energy system may naturally evolve over time without intervention from Governments as communities take unilateral action to reduce their emissions from stationary

energy. There is a movement across Australia at the community level working towards distributed energy solutions which is important to acknowledge. However a full and efficient transition of the energy supply chain is likely to require the union of many complementary policies. This is because of significant social and environmental costs associated with energy use that remain unpriced, and the current centralised supply system showing characteristics of inefficient technology lock-in, with modelling consistently demonstrating the significant untapped potential of distributed energy, and in this report, energy efficiency and DG in particular.

Overcoming technology lock-in requires targeted policy support for new technologies that allows them to emerge from a market niche to maturity. Technology support starts with research and development funding, creates subsidies for emerging technologies, then as the technology matures, makes use of market based and competition policies to drive efficiency improvements.

The majority of clean energy research and development priorities in Australia to date have focussed on addressing emissions caused by large scale generation. While this remains very important, modelling in this report shows that an efficient reduction of emissions requires a mix of technologies, with the role of distributed energy heightened by scenarios where promising future technologies such as carbon capture and storage fail to be deployed commercially. To mitigate the risk of stranded energy assets, more support for development of distributed energy technologies and systems may be required.

Policies are also needed to address systemic issues created by the dominance of the central supply model. Systemic issues include the lack of a pervasive skills base required to deliver distributed energy, the inability to capture the value of distributed energy solutions due to incomplete energy prices, and the decision making bias of customers.

A lack of skills is largely caused by the complex and disaggregated chain of businesses involved in designing and building the infrastructure that determines how we consume energy. From property developers, energy retailers, architects and network companies, no one business can capture all the value of distributed energy, therefore their incentive to pursue DG, energy efficiency or demand management is diluted. The flow on effect is a lack of commercial imperative to develop training and education that supports skills other than those required to perpetuate existing business models. To address this lack of skill development, policy is needed to signal the value of distributed energy, and create frameworks that allow its value to be captured. This will create innovation within the existing supply chain, but also ensure a competitive market for energy service delivery, with new energy supply models likely to emerge.

Policy and regulatory frameworks that start to address these issues have emerged in Australia including the use of energy white certificates to target energy efficiency at the household level through energy retailers, demand management incentive schemes for network companies to seek alternatives to network building, Smart Grid funding for a large scale demonstration of distributed energy technologies, building and appliance regulation, and the planned rollout of interval meters coupled with the potential for price deregulation to signal opportunities for more efficient energy services.

However there remains scope to refine those frameworks and in some cases expand their scope to allow the full value of distributed energy to be realised. To support this, better methodologies are required for valuing various distributed energy measures and incorporating them into policy and regulation including the value of time specific energy costs that distributed energy may avoid or substitute the value of environmental externalities and the value of enhanced energy system security and reliability that distributed energy can bring.

Systemic decision making bias in the energy supply chain appears to be caused by the interplay of inherent human decision making characteristics, the delivery model for centralised and decentralised energy and a lack of effective price signals for energy consumption. Consumers appear to systemically prefer to avoid loss as opposed to seek gain, and make imperfect trade offs between incurring costs today to securing benefits in the future. This decision making bias complements the central energy supply model which uses highly geared companies to finance capital intensive infrastructure, paid off over long time periods, resulting in low operating costs for energy. The low, flat tariff price signal encourages consumers to seek cheap, inefficient energy appliances, building design options and sub optimal energy supply options.

The decentralised model of high efficiency and local infrastructure ownership can entail high capital costs. This can affect the uptake of distributed energy as consumers typically lack access to cheap finance and inherently place high discount rates on their decisions. Consumer uptake may also be suppressed from uncertain payback periods that result from a combination of not knowing future energy prices, and not knowing how their energy demand may change over time.

Customers may also lack the ability to augment the infrastructure required to facilitate distributed energy, for instance they may not own the building they live or work in. They may also face significant information asymmetries and split incentives when integrating distributed energy with the grid, including navigating the grid connection process, and the inability to recover the time specific value of energy they avoid consuming, or substitute with a local alternative.

Addressing these systemic decision making biases can be achieved in a number of ways. Innovative models for delivering distributed energy can change the price signal seen by customers. Existing examples include bulk supply of technologies to reduce up front costs, or leasing models where distributed energy equipment is leased to customers for an annual fee or installed for no cost but paid for by energy cost savings.

They can also be addressed by using information and/or financial incentives, helping consumers make better decisions considering the true cost of operating energy consuming appliances. For example, decisions at the point of sale of energy appliances can be influenced, by providing efficient rebates for more efficient appliances. Rebates can be calculated to consider the time specific value of avoided energy costs not factored into energy prices, reflecting the significant cost difference between supplying base load power and temperature sensitive peak demand. Refining information disclosure requirements on buildings and appliances can also help consumers make better decisions about energy, for example by giving them clear guidance on likely avoided costs and payback periods, not just avoided consumption.

## SUMMARY

In part, because of the differing characteristics of centralised and decentralised supply models, distributed energy can often compete with the central supply model in green-field developments and where customers are forced to contribute significant capital costs up-front for infrastructure building. This is particularly evident in developing countries where centralised energy supply infrastructure has yet to be established. This should be considered an important signal as to the future value of distributed energy, with significant economic growth, and energy demand, likely to be driven by emerging economies such as China and India.

Importantly, distributed energy has significant potential in developed urban areas although capturing its value is made difficult because of the lack of clear price signals. As opposed to rural or green-field sites where the price signal for trade offs between centralised and decentralised energy models is often clear, in dense urban areas, upgrade and renewal of infrastructure is an ongoing processes with costs allocated across diverse customer bases. Coordinating decisions required to capitalise on avoiding asset renewal and upgrading is a difficult process, particularly if an optimal distributed energy solution is being sought across a network zone, as opposed to a single distributed energy solution such as DG to meet a very specific network constraint. Processes are underway to develop such signals through the AEMC and it will be important for policy makers and regulators to observe how the distributed energy market responds to these signals, and to refine signals where necessary.

Insights from social science can also help overcome some of decision making biases. Distributed energy product retailers and service providers can use social science to target consumers who are more likely to adopt distributed energy technologies and systems. Using insights documented in this report, awareness raising, education and messaging campaigns can be tailored to overcome a reluctance to adopt distributed energy, and help promote the values and attitudes that make consumers more likely to adopt distributed energy.

Fundamentally, in order to bring about the market transformation required to realise the value of distributed energy, long term policy with firm targets and commitments are required to give the market confidence about developing and deploying distributed energy solutions. The use of formal policy networks, where policy research, ideas and intentions can be shared, can help create the collaborative environment needed to transform the energy supply chain. These policy networks must involve multiple parties and be inter disciplinary in nature to capture the diverse range of stakeholders that influence energy supply options. Most importantly, policy networks need to bring together the complementary disciplines of economics, engineering and science so that decisions can be optimised considering a full diversity of variables.

Undoubtedly, transforming how energy is generated and consumed is one of the great challenges facing societies around the world. It is a challenge we believe distributed energy will play a major role in meeting.







### Contact Us

Phone: 1300 363 400

+61 3 9545 2176

Email: [enquiries@csiro.au](mailto:enquiries@csiro.au)

Web: [www.csiro.au](http://www.csiro.au)

### Your CSIRO

Australia is founding its future on science and innovation. Its national science agency, CSIRO, is a powerhouse of ideas, technologies and skills for building prosperity, growth, health and sustainability. It serves governments, industries, business and communities across the nation.